

# JANUS PUMPS

SEAWATER  
AXIAL  
PISTON  
PUMPS

The  
**Water**  
**Hydraulics**  
Co. Ltd.

PUTTING WATER TO WORK



# CONTENTS

<b>1. INTRODUCTION</b>	<b>3</b>
1.1 OVERVIEW	3
1.2 BENEFITS	3
<b>2. DESIGN OVERVIEW</b>	<b>4</b>
2.1 INLET CONDITIONS - 3 PORT DESIGN	4
2.2 PUMP ORDERING CODE	5
2.3 PUMP SPECIFICATIONS	5
2.4 FILTRATION & FLUSHING REQUIREMENTS	6
<b>3. SEAWATER PUMP RANGE</b>	<b>7</b>
3.1 P6	7
3.1.1 SPECIFICATION	7
3.1.2 GENERAL ASSEMBLY DRAWING	7
3.1.3 PORT DIMENSIONS (ACW CONFIGURATION)	7
3.1.4 P6 PERFORMANCE DATA	8
3.2 P15	10
3.2.1 SPECIFICATION	10
3.2.2 GENERAL ASSEMBLY DRAWING	10
3.2.3 PORT DIMENSIONS (ACW CONFIGURATION)	10
3.2.4 P15 PERFORMANCE DATA	11
3.3 P30	13
3.3.1 SPECIFICATION	13
3.3.2 GENERAL ASSEMBLY DRAWING	13
3.3.3 PORT DIMENSIONS (ACW CONFIGURATION)	13
3.3.4 P30 PERFORMANCE DATA	14
3.4 P60	16
3.4.1 SPECIFICATION	16
3.4.2 GENERAL ASSEMBLY DRAWING	16
3.4.3 PORT DIMENSIONS (ACW CONFIGURATION)	16
3.4.4 P60 PERFORMANCE DATA	17
3.5 P180	19
3.5.1 SPECIFICATIONS	19
3.5.2 GENERAL ASSEMBLY DRAWING	19
3.5.3 PORT DIMENSIONS (ACW CONFIGURATION)	19
3.5.4 P180 PERFORMANCE DATA	20
3.6 P300	22
3.6.1 SPECIFICATION	22
3.6.2 GENERAL ASSEMBLY DRAWING	22
3.6.3 PORT DIMENSIONS (ACW CONFIGURATION)	22
3.6.4 P300 PERFORMANCE DATA	23
3.7 P600	25
3.7.1 SPECIFICATION	25
3.7.2 GENERAL ASSEMBLY DRAWING	25
3.7.3 PORT DIMENSIONS (ACW CONFIGURATION)	25
3.7.4 P600 PERFORMANCE DATA	26
<b>4. SYSTEM DESIGN</b>	<b>28</b>
4.1 CIRCUIT EXAMPLE	28
4.2 ELECTRIC MOTOR	29
4.3 INSTALLATION	29
<b>5. SERVICING</b>	<b>30</b>
5.1 SERVICE SCHEDULE	30
<b>6. DISCLAIMER</b>	<b>31</b>
<b>7. CONTACT DETAILS</b>	<b>31</b>

# SEAWATER AXIAL PISTON PUMPS

## 1. INTRODUCTION

### 1.1 Overview

The high-pressure Janus seawater axial piston pump range is optimised for reverse osmosis systems, with a design versatile enough to support numerous additional high-pressure applications.

The Janus seawater pumps operate as positive-displacement units, moving a defined volume of water with each piston cycle. As a result, the pump's output flow is directly proportional to the motor's rotational speed.

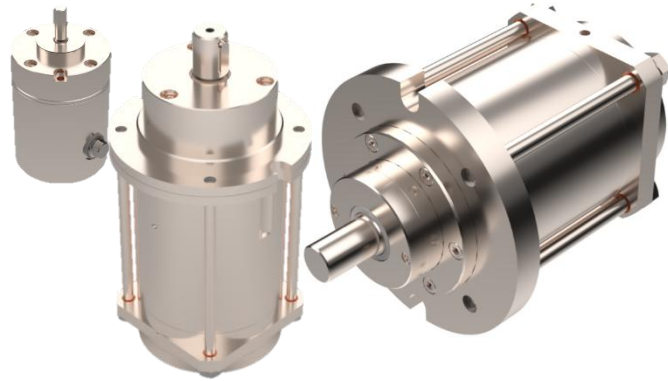

### 1.2 Benefits

#### ✓ No Risk of Contamination

Our Janus axial piston pumps are totally oil free. As a result of employing advanced materials, high velocity and loaded sliding surfaces, the range of pumps can operate effectively with seawater as their only coolant/lubricant therefore, this removes the potential for cross contamination of the system fluid or lubricating oil.

#### ✓ Safe & Efficient

The pumps utilise technologies that suppress vibration and deliver low-noise, high-efficiency performance. Their multi-piston configuration, combined with high rotational speeds, produces exceptionally low pulsation. This enables a compact, lightweight design that offers safe operation and reduced operating costs. For even more long-term cost-effective solutions, please refer to our integral energy-recovery models, the *Janus Power Centre* catalogues, or consult TWHC.

#### ✓ Easy Installation, Operation & Maintenance

Standardised porting and mounting solutions ensure straightforward installation, and the accompanying detailed manual & service guide helps maintain reliable, high-level performance. Accurate flow metering is simply achieved with the control of the output shaft speed.

#### ✓ Reliability

All units are manufactured and tested on-site to the published performance data, ensuring high quality is kept consistent. All materials used for the seawater pumps are selected to provide excellent corrosion resistance while remaining cost-effective:

1. **Duplex Build** – All water-contacting components are manufactured from bar-stock Duplex 2205 (with no cast parts), delivering maximum corrosion resistance for extreme salt concentrations.
2. **Hybrid Build** – Components are produced in 316L stainless steel, with strategically selected internal parts—such as bearing surfaces—manufactured from bar-stock Duplex 2205.

# SEAWATER AXIAL PISTON PUMPS

## 2. DESIGN OVERVIEW

### 2.1 Inlet Conditions - 3 Port Design

Our 3-port boosted pumps are designed for operation with a pressurised feed supply. The minimum inlet pressure is determined by pump shaft speed. As a guide:

- P6 – P300 models: Minimum inlet pressure 3.0 – 3.6 Bar
- P600 models: Minimum inlet pressure 3.5 – 4.1 Bar

The 3-port design isolates the feed water from the internal leakage flow, which must be routed to a low-pressure drain or sump. This offers several performance advantages:

1. Reduced power requirement: The pump only needs to generate the differential pressure. For example, with a 5 Bar feed and 60 Bar discharge, the pump produces only the remaining 55 Bar.
2. Improved mechanical seal life: Because the feed pressure and casing (leakage) pressure are separated, the shaft seal operates at a significantly lower pressure. This reduces wear, minimises maintenance, and prevents low-pressure cavitation.

***A constant positive inlet pressure must be maintained, of at least 2.5 Bar above the casing ("T") pressure always.***

All seawater pumps are designed to be operated anticlockwise unless specifically stated or requested. Direction of rotation is based on looking at the shaft of the pump, see the diagram below.

DIRECTION OF ROTATION  
 ANTI CLOCKWISE, VIEWED  
 ON PUMP SHAFT

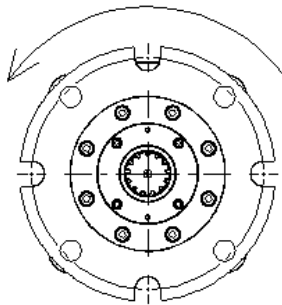

# SEAWATER AXIAL PISTON PUMPS

## 2.2 Pump Ordering Code

All Water Hydraulics products each have their own individual identification number. Below is a diagram which explains how to read the number.

A typical seawater pump part number would look like the following:

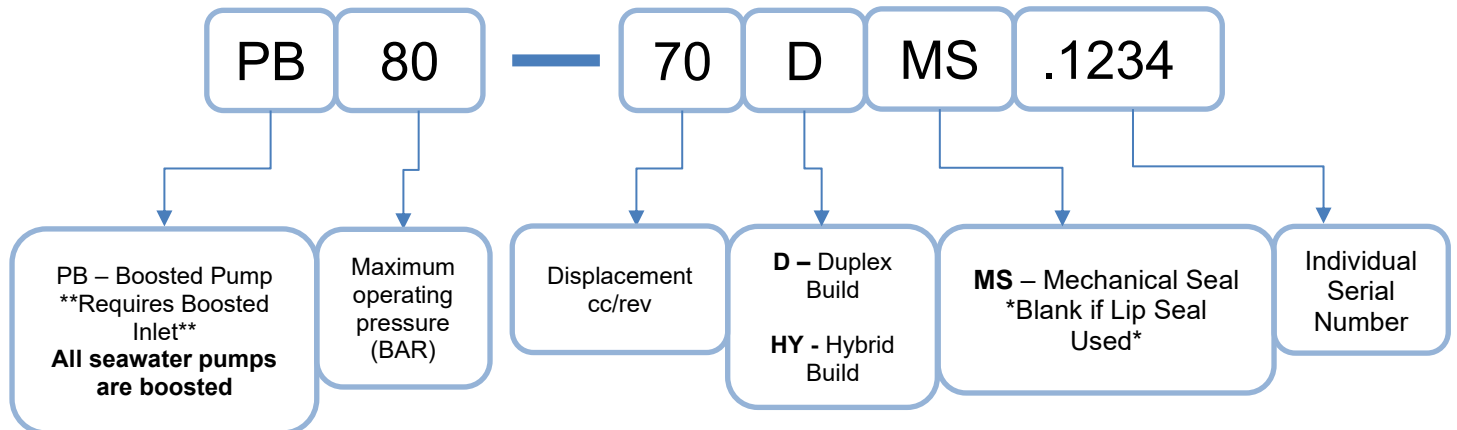

*Example: A pump operating at 80 Bar on seawater, with a displacement of 70cc/Rev, duplex build & mechanical seal:*

**Ordering code: PB80-70DMS**

## 2.3 Pump Specifications

The table below outlines specifications for the seawater pumps. For more information and performance characteristics, see the relevant pump catalogue on The Water Hydraulics Company website where a catalogue can be downloaded.

		SPECIFICATION						
Pumps		P6	P15	P30	P60	P180	P300	P600
Displacement (cc/rev)	Max:	6.0	19.0	35.0	80.0	225	286	625
	Min:	4.6	12.0	23.0	51.0	135	-	390
Max. RPM	Boosted: *	2000	2200	2000	2000	2000	2000	1250
Max. Input Power (kW)		1.8	6.2	10.4	23.8	66.7	84.8	115.8
Max. Water Flow (m <sup>3</sup> /hr)		0.72	2.51	4.2	9.6	27	34.3	46.8
Max. Cont. Pressure (Barg)		80	80	80	80	80	80	80
Weight (kg)		2.2	6	10	19	82	82	120
Temperature (°C)	Max: **	50	50	50	50	50	50	50
	Min: ***	2	2	2	2	2	2	2

# SEAWATER AXIAL PISTON PUMPS

## 2.4 Filtration & Flushing Requirements

All incoming water to the pump must be pre-filtered to achieve warranty and the service intervals stated, the pump requires filter to an absolute rating of 10 micron (10  $\mu$ ) with a Beta Ratio > 5000.

Beta Ratio	How Many Particles of a Given Size Will Pass Through the Filter?	Filter Efficiency
2	1 out of every 2 particles	50%
10	1 out of every 10 particles	90%
20	1 out of every 20 particles	95%
75	1 out of every 75 particles	98.7%
100	1 out of every 100 particles	99%
200	1 out of every 200 particles	99.5%
1,000	1 out of every 1,000 particles	99.9%
2,000	1 out of every 2,000 particles	99.95%
<b>5,000</b>	<b>1 out of every 5,000 particles</b>	<b>99.98%</b>
10,000	1 out of every 10,000 particles	99.99%

The Beta Ratio is a measure of the filter's efficiency; the pump requires a Beta Ratio > 5000. This ensures the filtration removes 99.98% of the particles 10 $\mu$  or larger with only 1 out of every 5,000 particles will pass through the filter ensuring the maximum life of the assembly.

We would advise all desalination pumps are flushed on a routine basis. Any period of non-operation (short or long) the system must run on permeate to ensure the seawater is flushed from the system. Even with the adoption of such high-grade corrosion material, we would advise a weekly (if not sooner) fresh water flushing regime is undertaken especially if the system will be non-operational for any period.

# SEAWATER AXIAL PISTON PUMPS

## 3. SEAWATER PUMP RANGE

### 3.1 P6

#### 3.1.1 Specification

SPECIFICATION			
Displacement (cc/rev)		4.6	6.0
Max. RPM	Boosted: *	2000	2000
Max. Input Power (kW)		1.4	1.8
Max. Water Flow (m <sup>3</sup> /hr)		0.55	0.72
Max. Cont. Pressure (Barg)		80	80
Weight (kg)		2.2	2.2
Temperature (°C)	Max: **	50	50
	Min: ***	2	2

#### 3.1.2 General Assembly Drawing

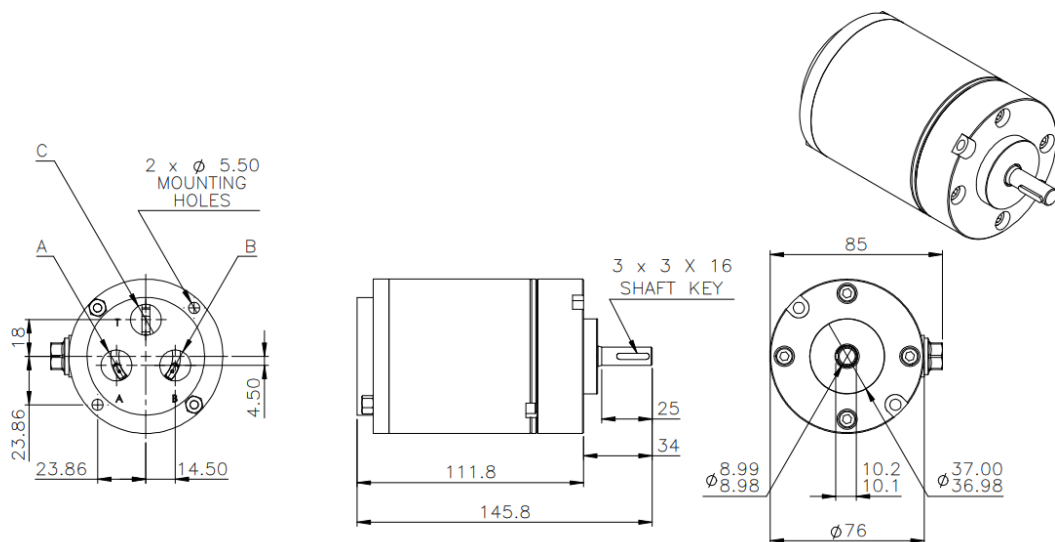

#### 3.1.3 Port Dimensions (ACW Configuration)

Position	Description	Size
A	Low Pressure In	3/8" BSPP
B	High Pressure Out	3/8" BSPP
C	Tank Return Line	3/8" BSPP

# SEAWATER AXIAL PISTON PUMPS

## 3.1.4 P6 Performance Data

### Output Flow

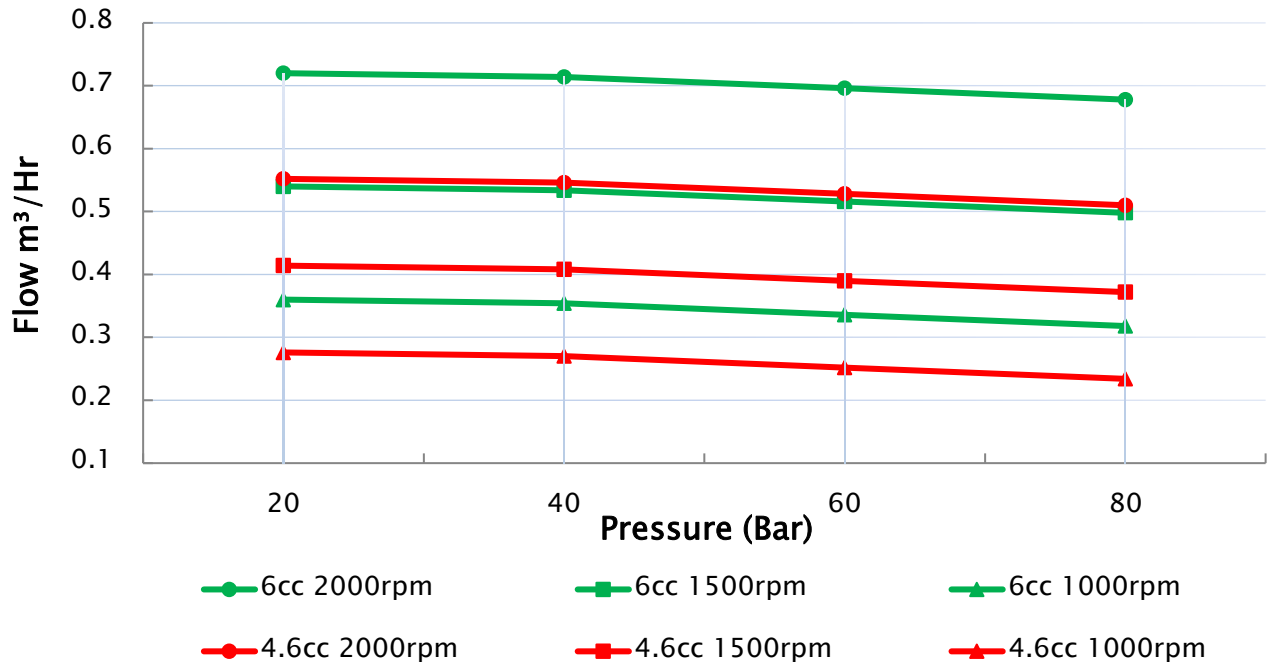

### Input Power

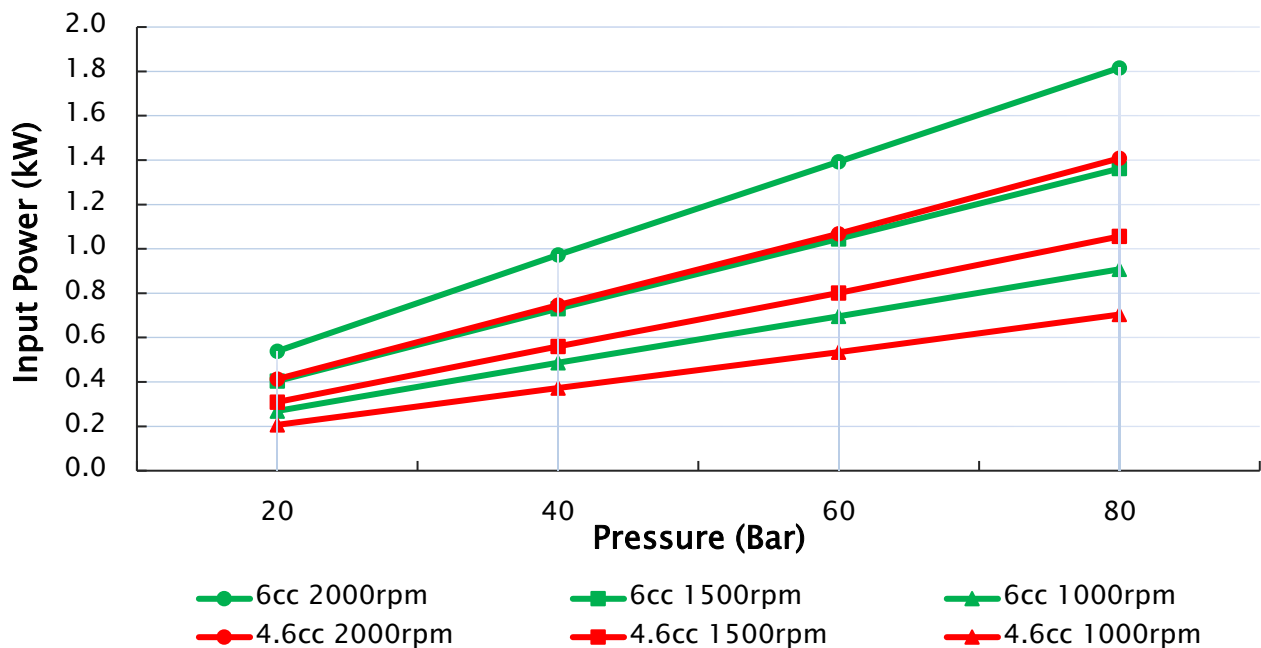

# SEAWATER AXIAL PISTON PUMPS

## Input Torque

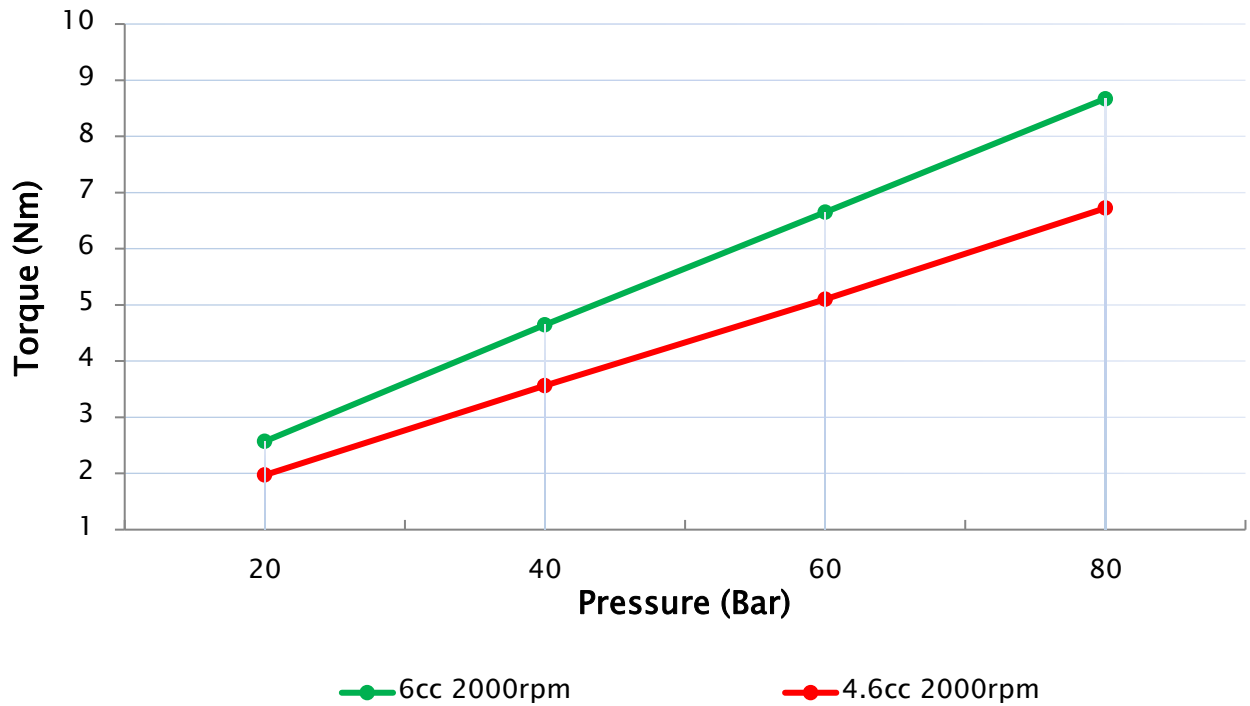

## Overall Efficiency

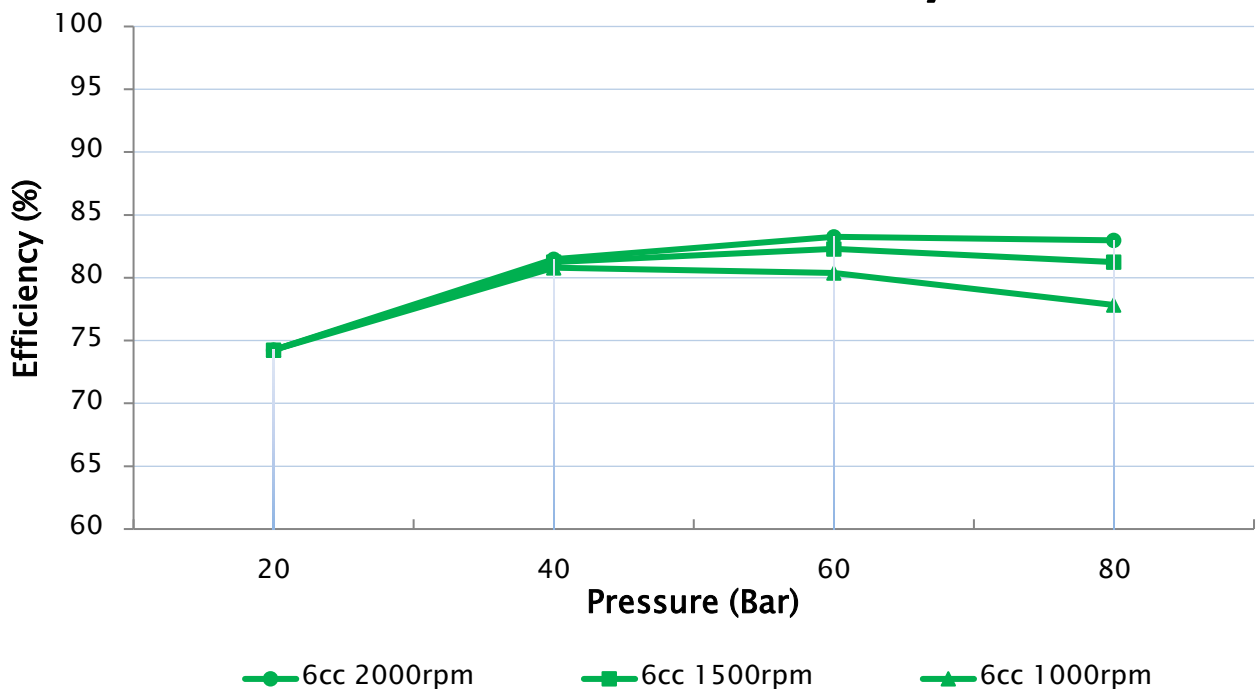

# SEAWATER AXIAL PISTON PUMPS

## 3.2 P15

### 3.2.1 Specification

SPECIFICATION				
Displacement (cc/rev)		12	15	19
Max. RPM	Boosted: *	2200	2200	2200
Max. Input Power (kW)		4	4.9	6.2
Max. Water Flow (m <sup>3</sup> /hr)		1.58	1.98	2.51
Max. Cont. Pressure (Barg)		80	80	80
Weight (kg)		6	6	6
Temperature (°C)	Max: **	50	50	50
	Min: ***	2	2	2

### 3.2.2 General Assembly Drawing

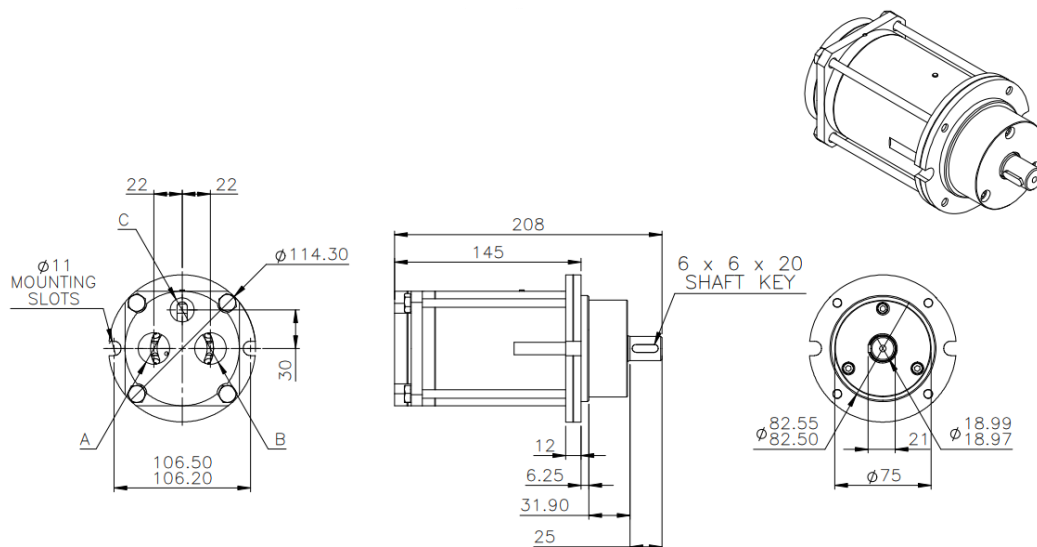

### 3.2.3 Port Dimensions (ACW Configuration)

Position	Description	Size
A	Low Pressure In	3/4" BSPP
B	High Pressure Out	3/4" BSPP
C	Tank Return Line	1/2" BSPP

# SEAWATER AXIAL PISTON PUMPS

## 3.2.4 P15 Performance Data

### Output Flow

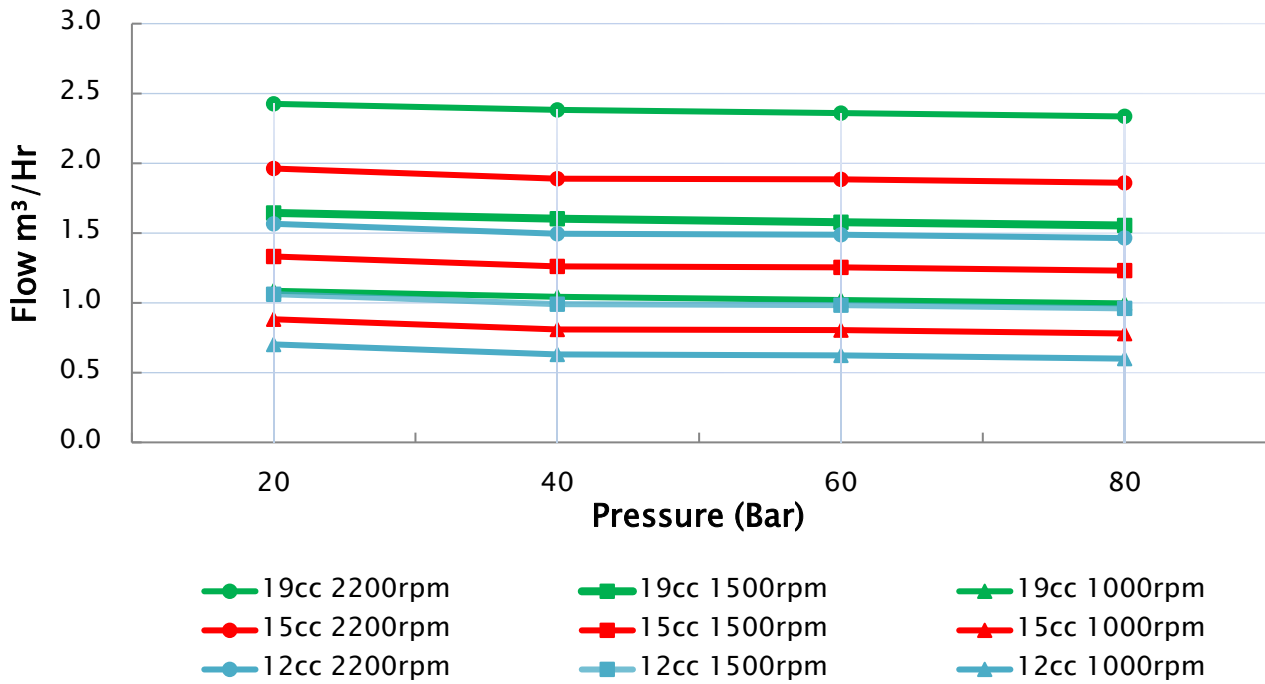

### Input Power

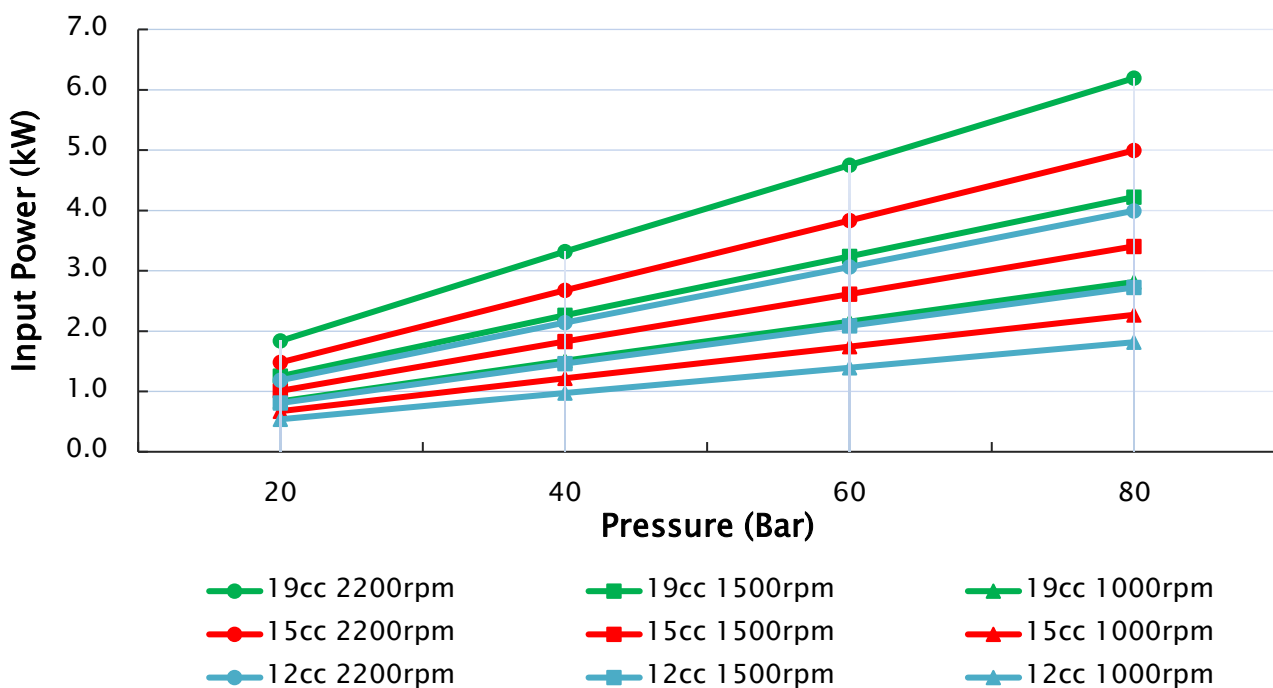

# SEAWATER AXIAL PISTON PUMPS

## Input Torque

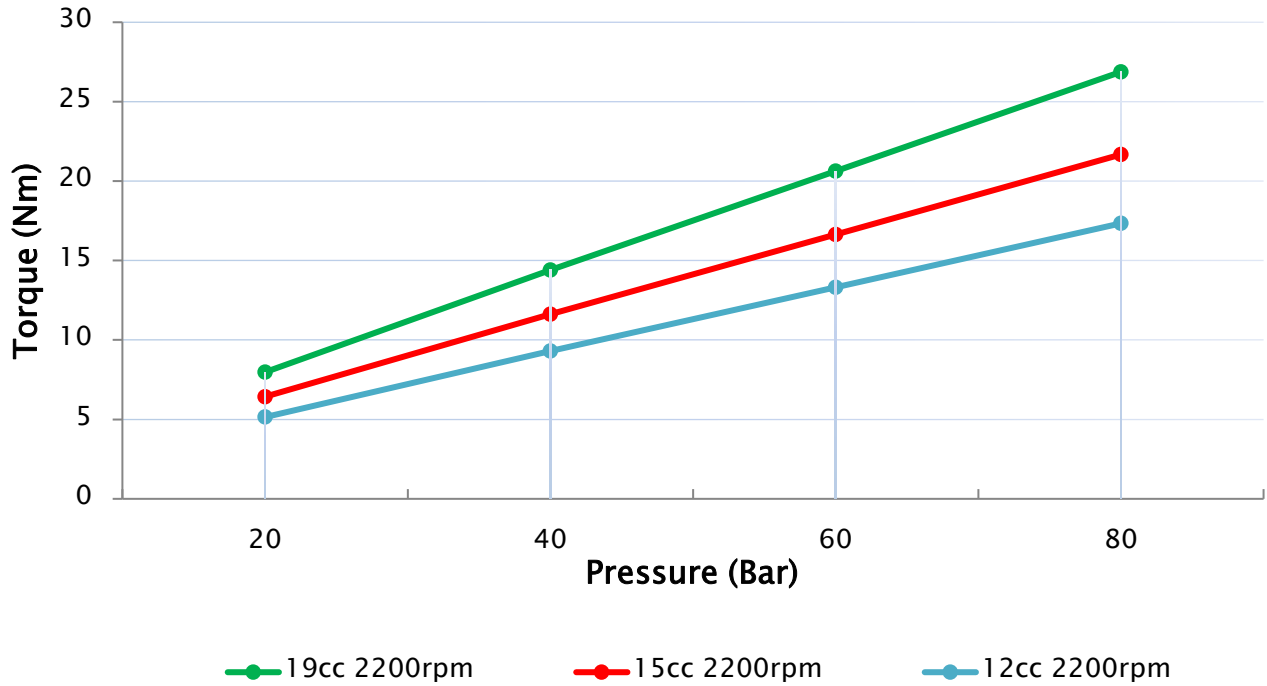

## Overall Efficiency

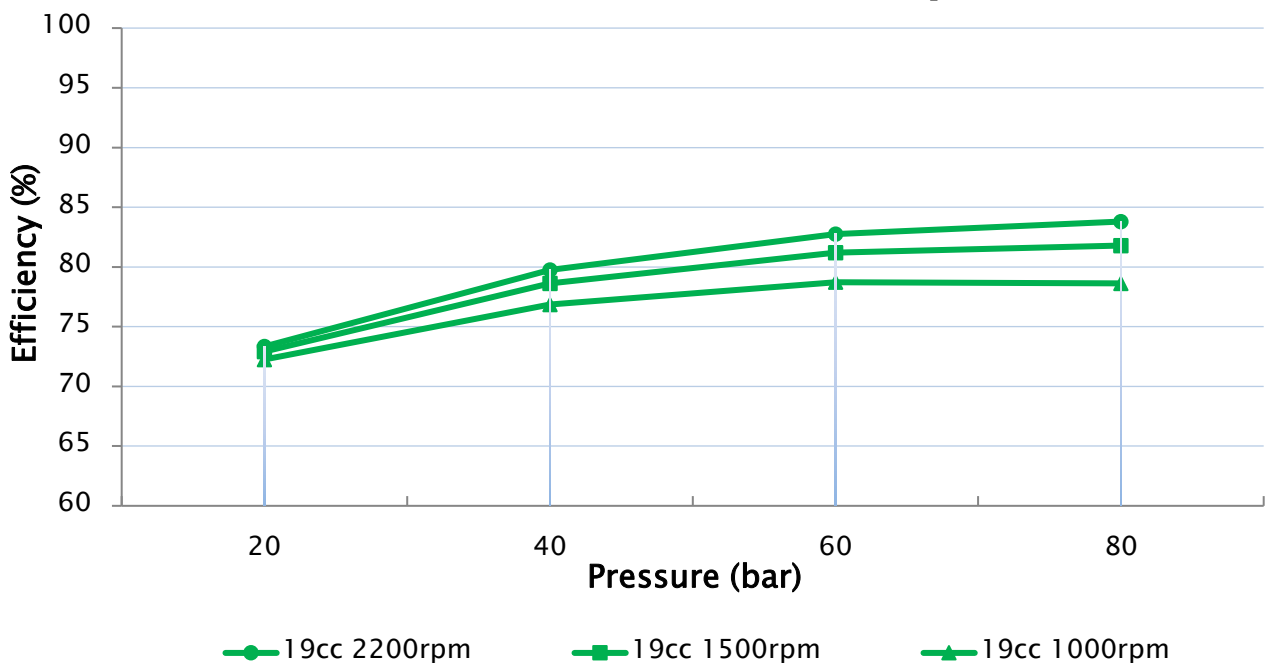

# SEAWATER AXIAL PISTON PUMPS

## 3.3 P30

### 3.3.1 Specification

SPECIFICATION				
Displacement (cc/rev)		23	30	35
Max. RPM	Boosted: *	2000	2000	2000
Max. Input Power (kW)		6.9	8.9	10.4
Max. Water Flow (m <sup>3</sup> /hr)		2.76	3.6	4.2
Max. Cont. Pressure (Barg)		80	80	80
Weight (kg)		10	10	10
Temperature (°C)	Max: **	50	50	50
	Min: ***	2	2	2

### 3.3.2 General Assembly Drawing

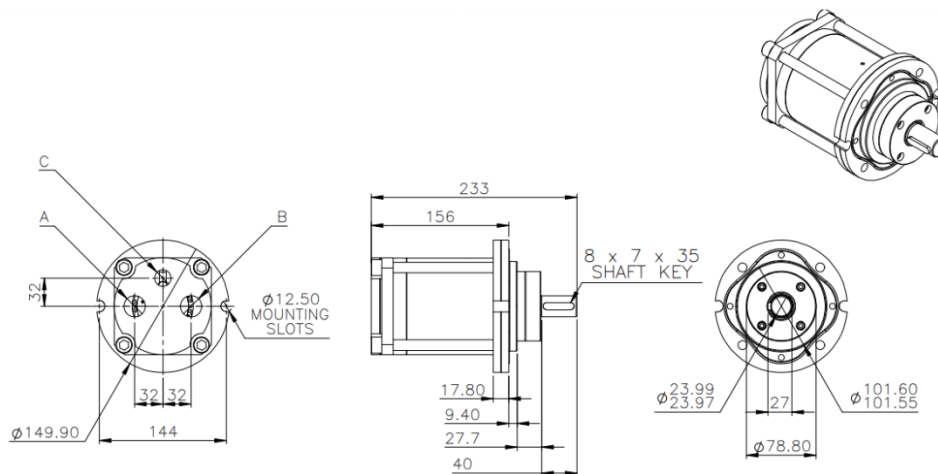

### 3.3.3 Port Dimensions (ACW Configuration)

Position	Description	Size
A	Low Pressure In	3/4" BSPP
B	High Pressure Out	3/4" BSPP
C	Tank Return Line	1/2" BSPP

# SEAWATER AXIAL PISTON PUMPS

## 3.3.4 P30 Performance Data

### Output Flow

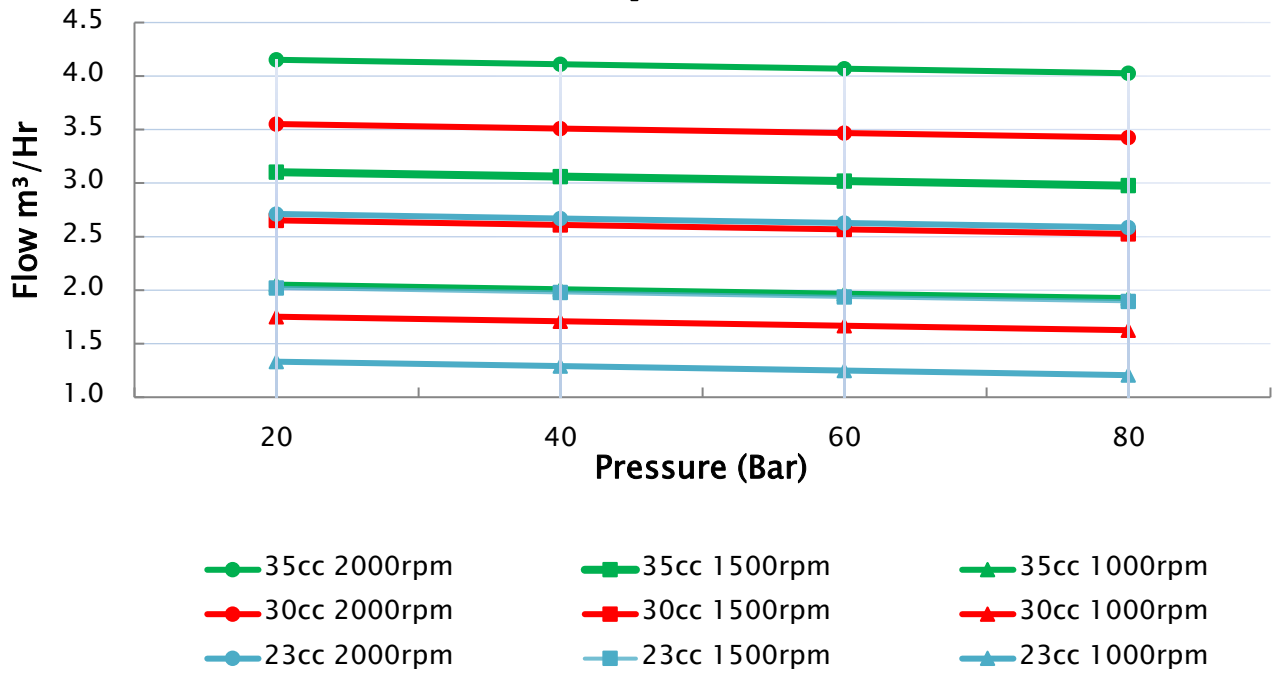

### Input Power

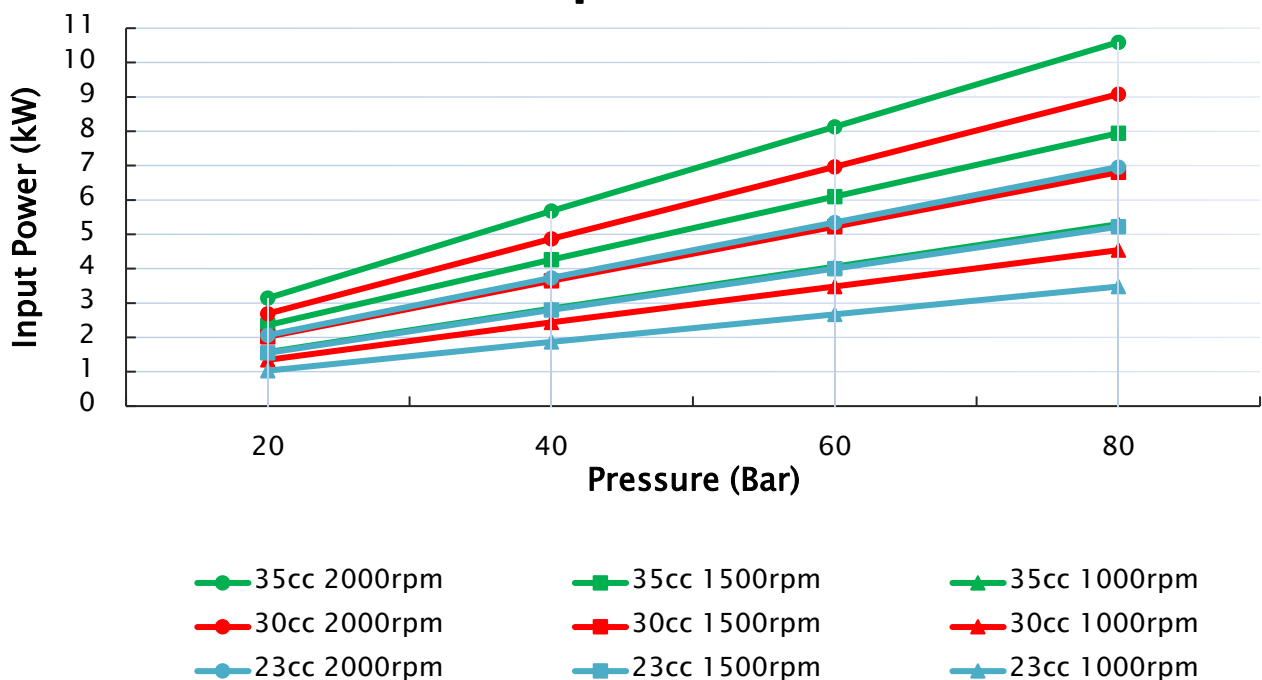

# SEAWATER AXIAL PISTON PUMPS

## Input Torque

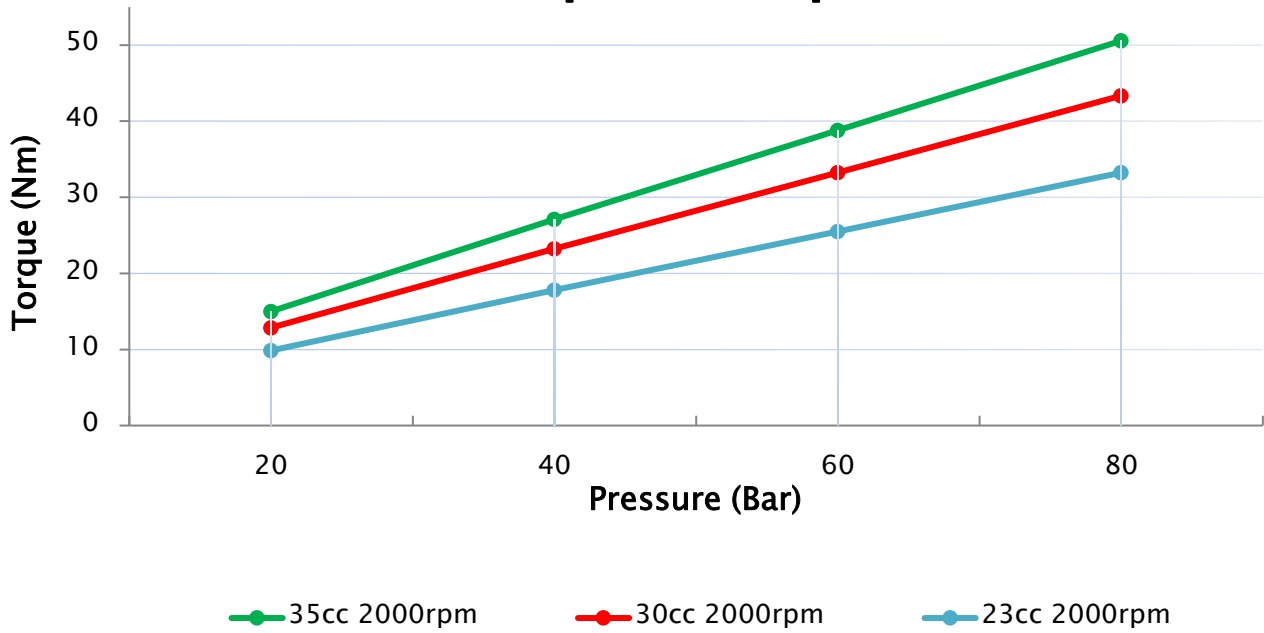

## Overall Efficiency

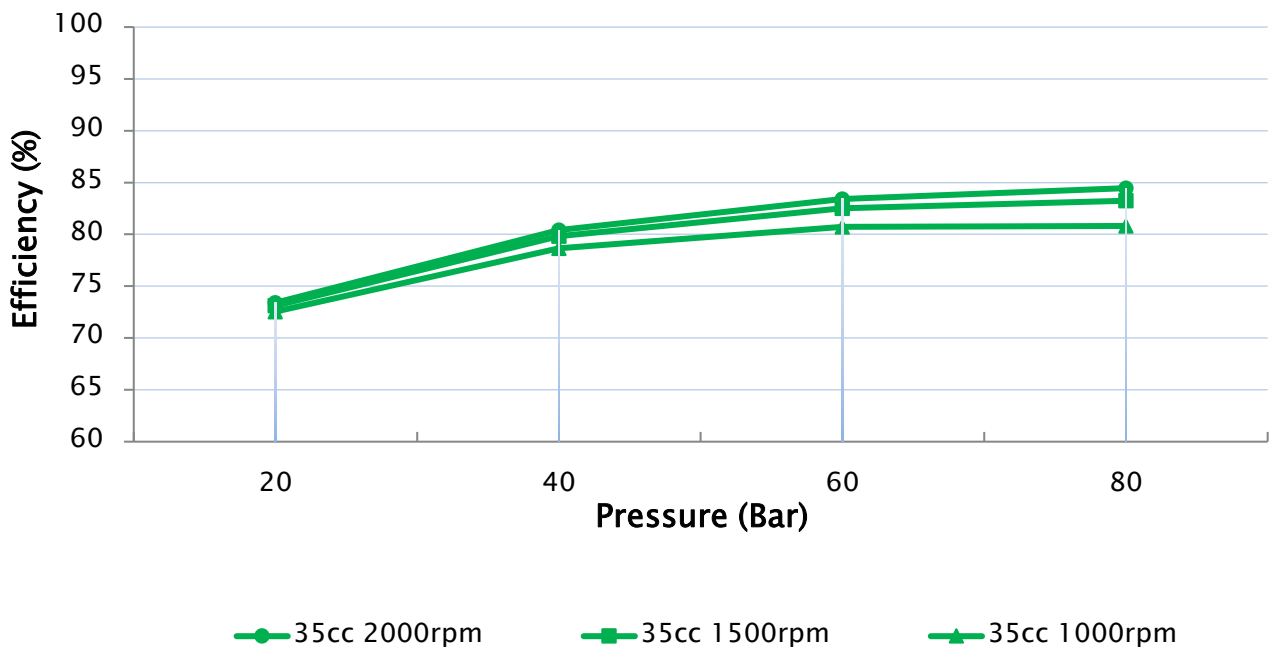

# SEAWATER AXIAL PISTON PUMPS

## 3.4 P60

### 3.4.1 Specification

SPECIFICATION					
Displacement (cc/rev)		51	63	70	80
Max. RPM	Boosted: *	2000	2000	2000	2000
Max. Input Power (kW)		15.2	18.7	20.8	23.8
Max. Water Flow (m <sup>3</sup> /hr)		6.1	7.5	8.4	9.6
Max. Cont. Pressure (Barg)		80	80	80	80
Weight (kg)		19	19	19	19
Temperature (°C)	Max: **	50	50	50	50
	Min: ***	2	2	2	2

### 3.4.2 General Assembly Drawing

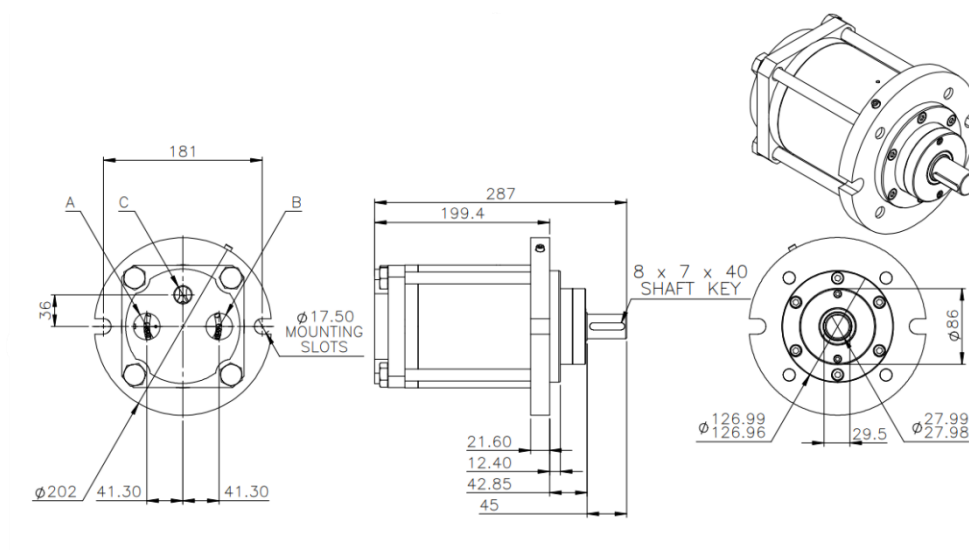

### 3.4.3 Port Dimensions (ACW Configuration)

Position	Description	Size
A	Low Pressure In	1" BSPP
B	High Pressure Out	1" BSPP
C	Tank Return Line	1/2" BSPP

# SEAWATER AXIAL PISTON PUMPS

## 3.4.4 P60 Performance Data

### Output Flow

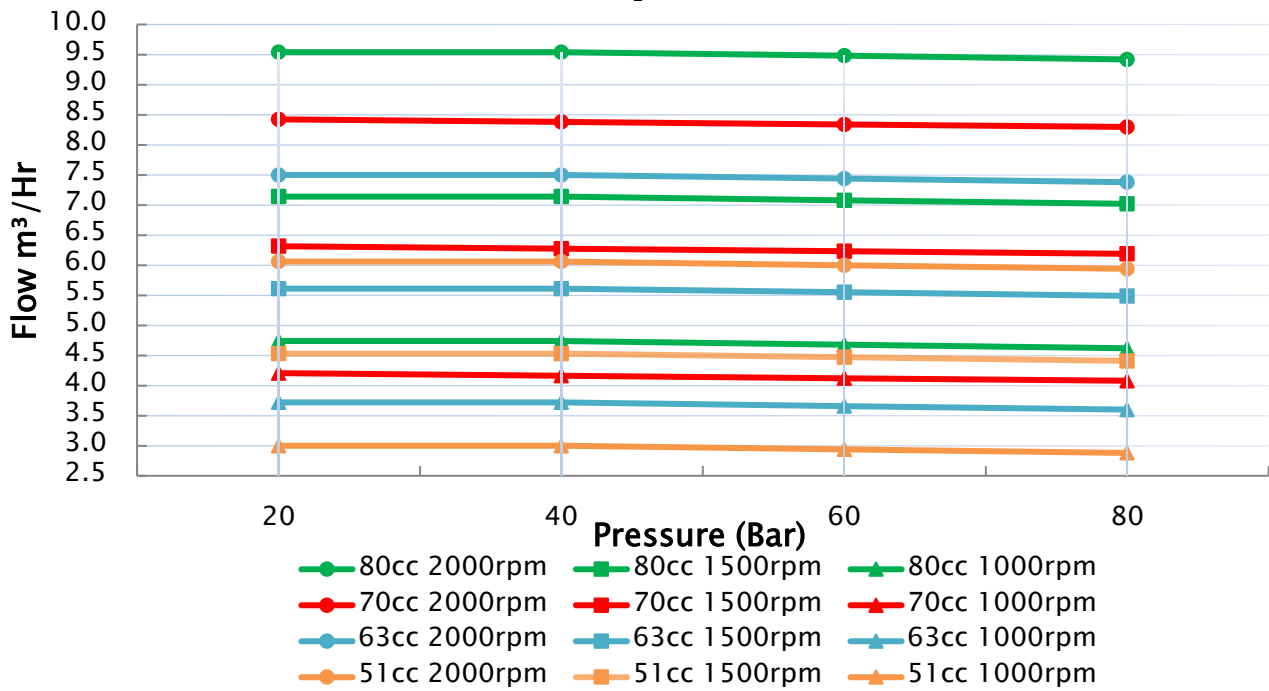

### Input Power

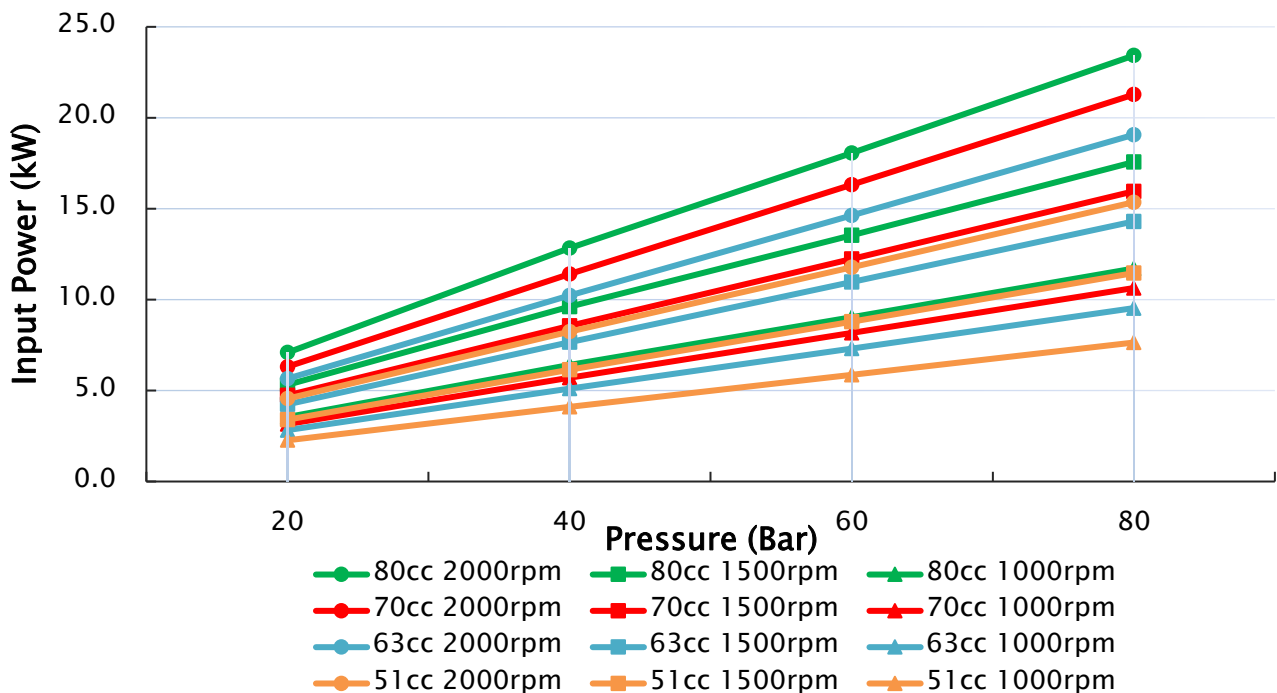

# SEAWATER AXIAL PISTON PUMPS

## Input Torque

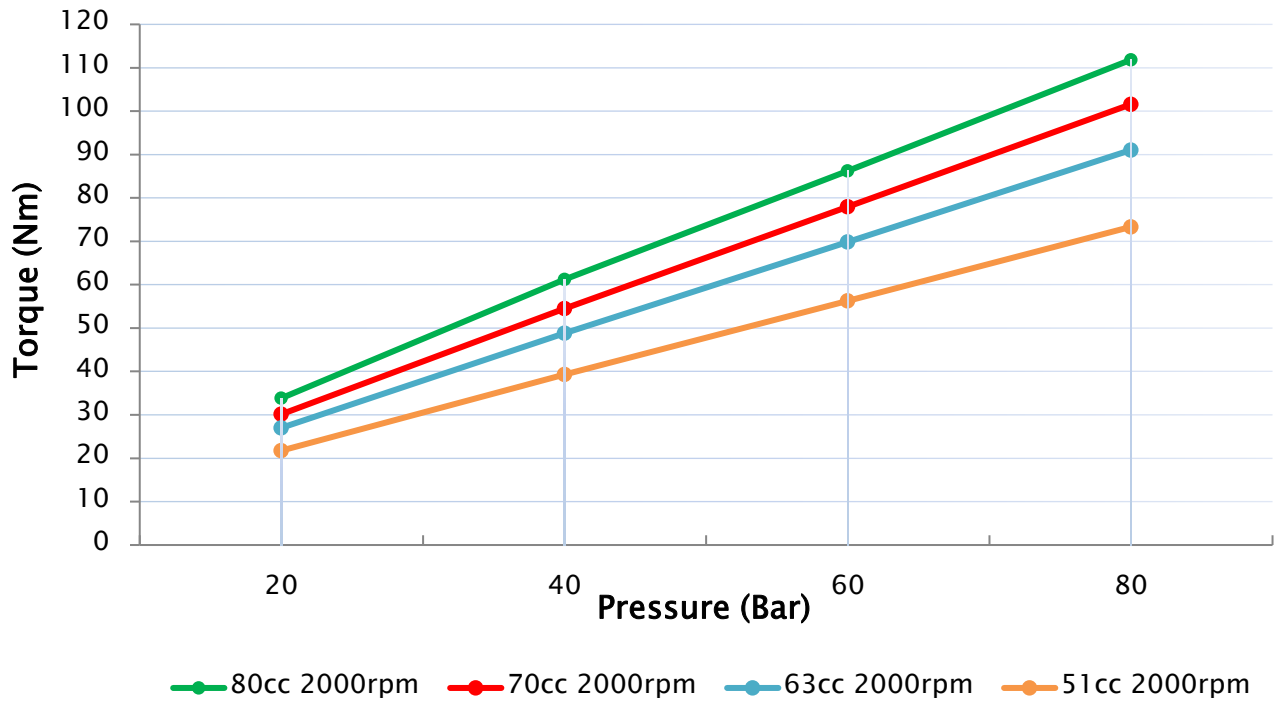

## Overall Efficiency

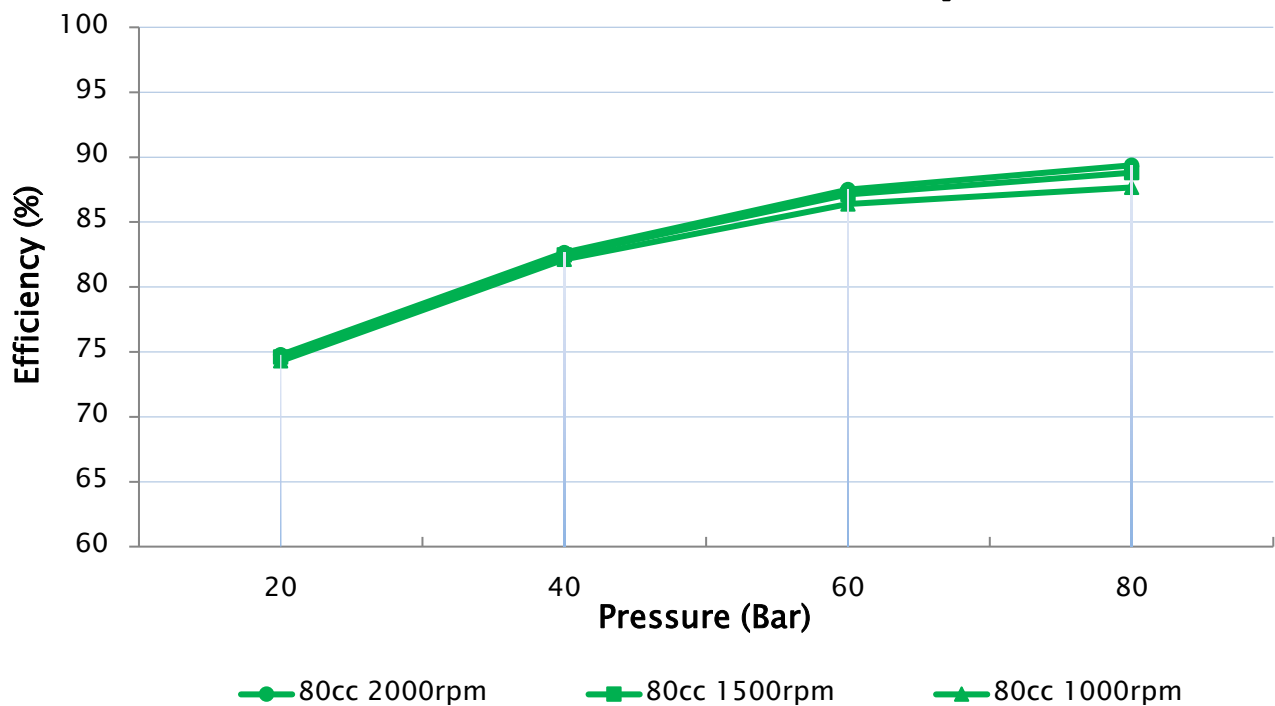

# SEAWATER AXIAL PISTON PUMPS

## 3.5 P180

### 3.5.1 Specifications

SPECIFICATION				
Displacement (cc/rev)		135	180	225
Max. RPM	Boosted: *	2000	2000	2000
Max. Input Power (kW)		40.0	53.4	66.7
Max. Water Flow (m <sup>3</sup> /hr)		16.2	21.6	27.0
Max. Cont. Pressure (Barg)		80	80	80
Weight (kg)		82	82	82
Temperature (°C)	Max: **	50	50	50
	Min: ***	2	2	2

### 3.5.2 General Assembly Drawing

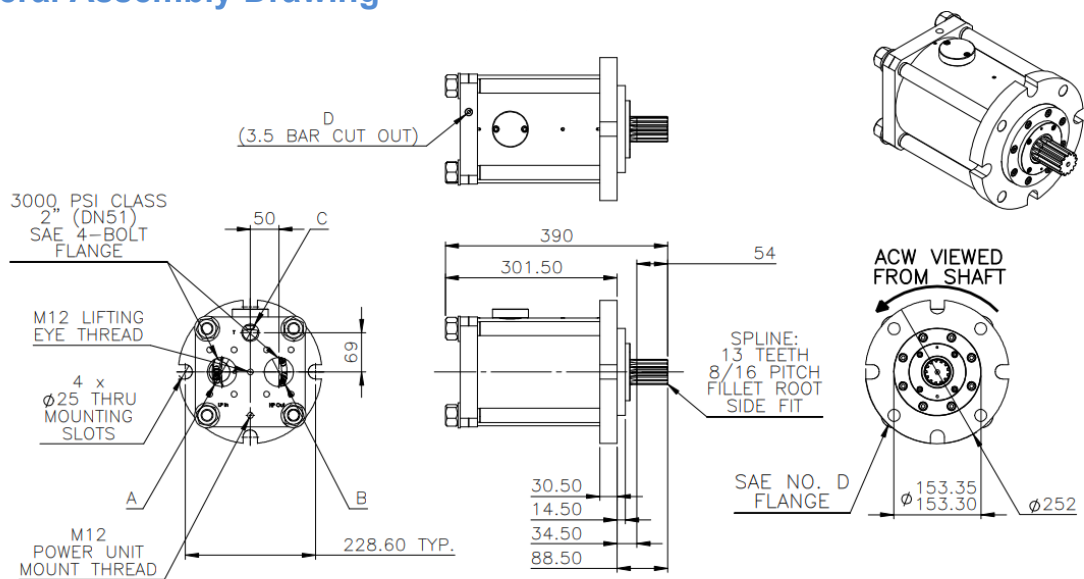

### 3.5.3 Port Dimensions (ACW Configuration)

Position	Description	Size
A	Low Pressure In	2" 3000 PSI CLASS SAE 4-BOLT FLANGE
B	High Pressure Out	2" 3000 PSI CLASS SAE 4-BOLT FLANGE
C	Case Drain	1" BSPP FEMALE
D	Inlet Pressure Switch Port	1/4" BSPP FEMALE

# SEAWATER AXIAL PISTON PUMPS

## 3.5.4 P180 Performance Data

### Output Flow

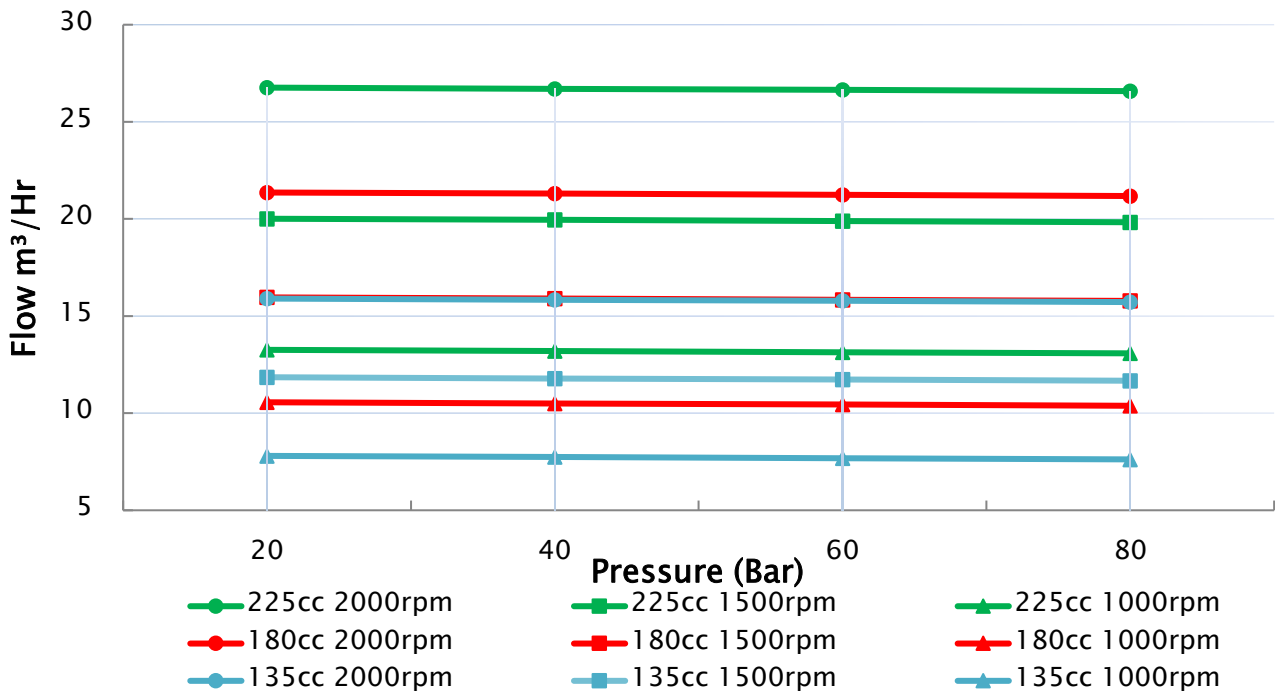

### Input Power

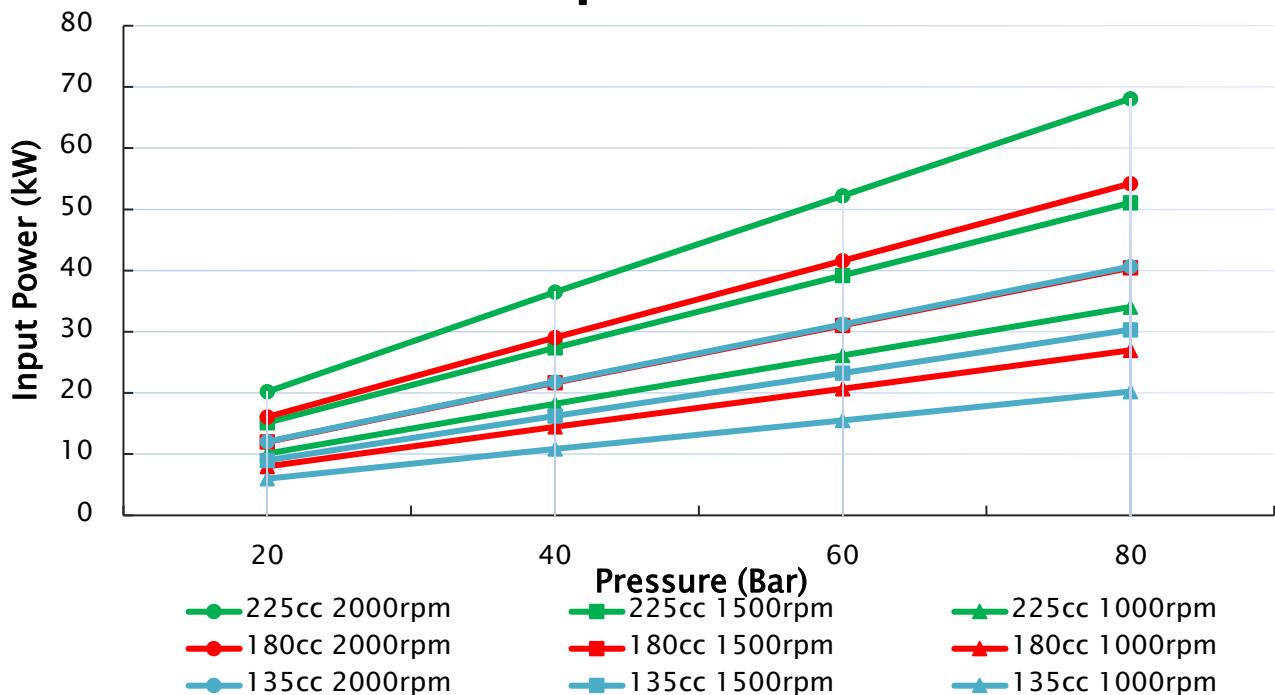

# SEAWATER AXIAL PISTON PUMPS

## Input Torque

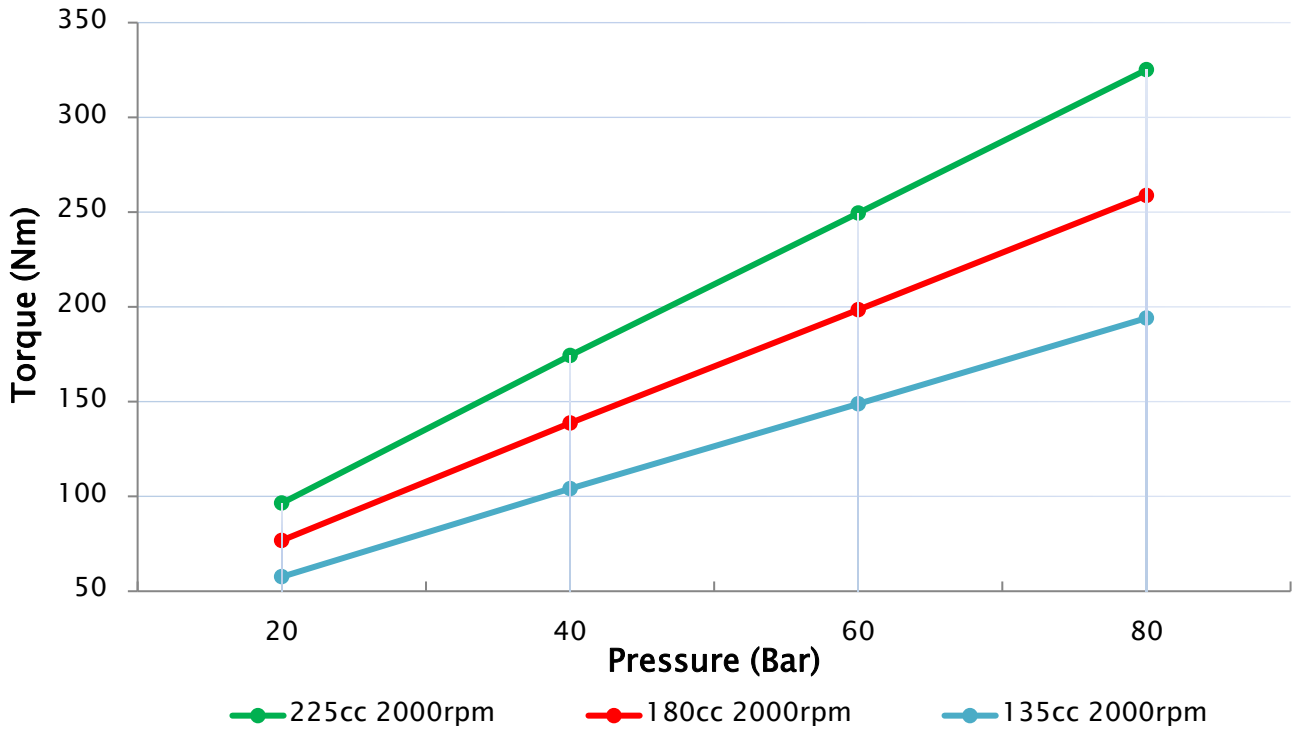

## Overall Efficiency

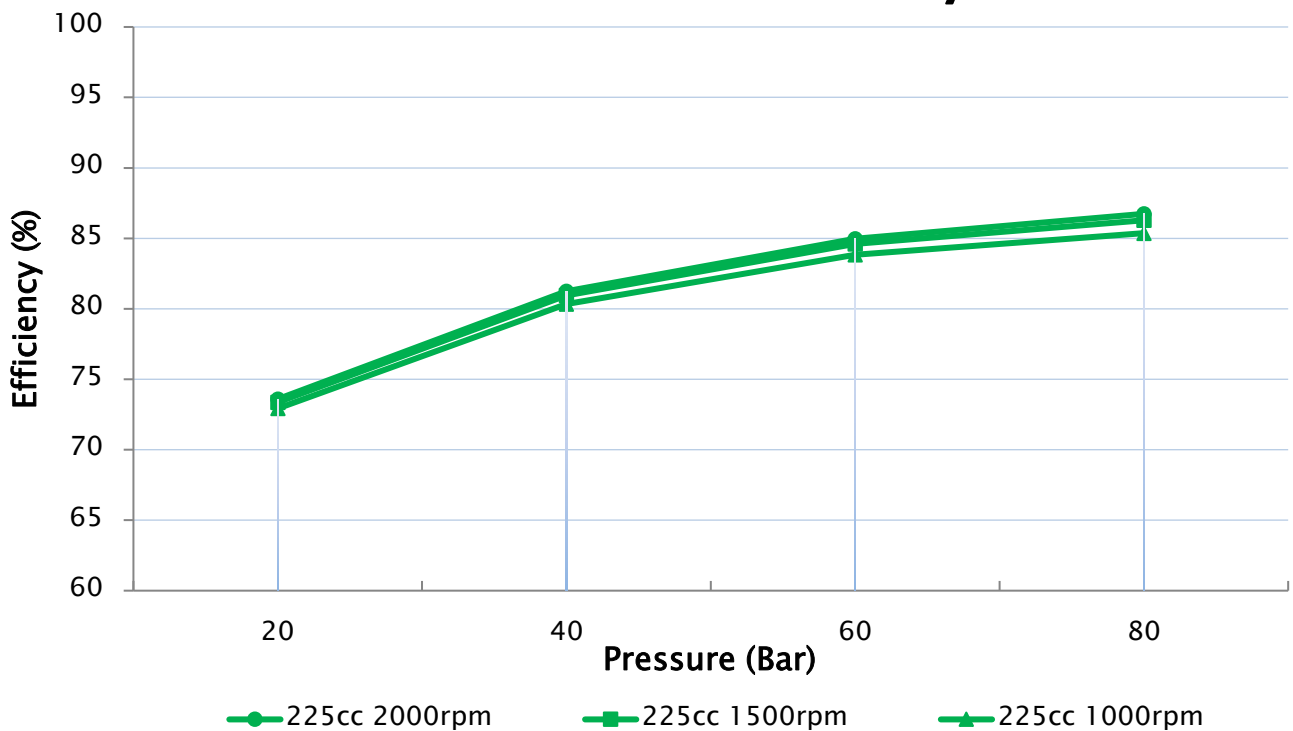

# SEAWATER AXIAL PISTON PUMPS

## 3.6 P300

### 3.6.1 Specification

SPECIFICATION		
Displacement (cc/rev)		286
Max. RPM	Boosted: *	2000
Max. Input Power (kW)		84.8
Max. Water Flow (m <sup>3</sup> /hr)		34.3
Max. Cont. Pressure (Barg)		80
Weight (kg)		82
Temperature (°C)	Max: **	50
	Min: ***	2

### 3.6.2 General Assembly Drawing

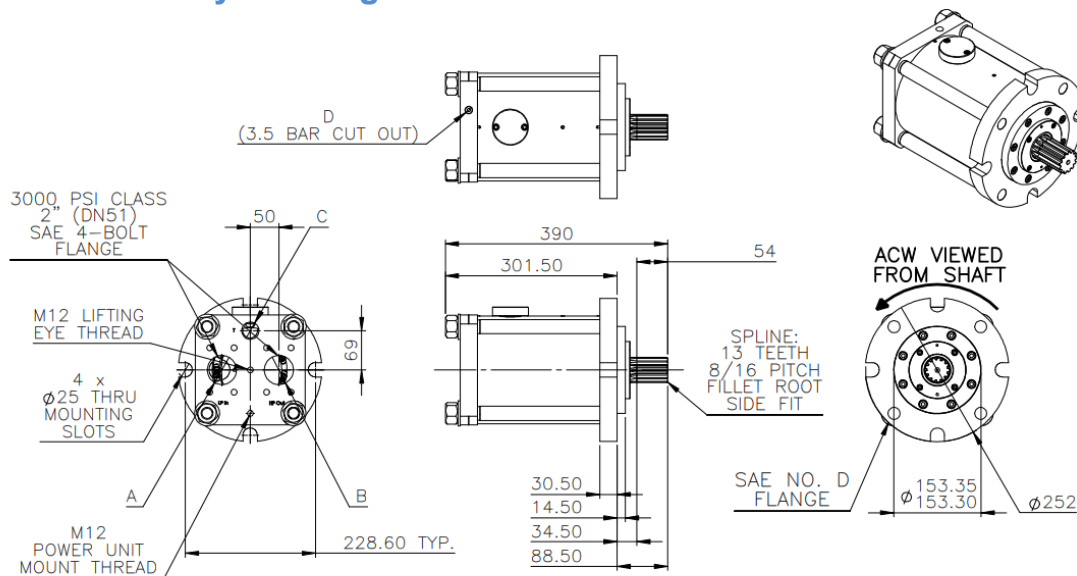

### 3.6.3 Port Dimensions (ACW Configuration)

Position	Description	Size
A	Low Pressure In	2" 3000 PSI CLASS SAE 4-BOLT FLANGE
B	High Pressure Out	2" 3000 PSI CLASS SAE 4-BOLT FLANGE
C	Case Drain	1" BSPP FEMALE
D	Inlet Pressure Switch Port	1/4" BSPP FEMALE

# SEAWATER AXIAL PISTON PUMPS

## 3.6.4 P300 Performance Data

### Output Flow

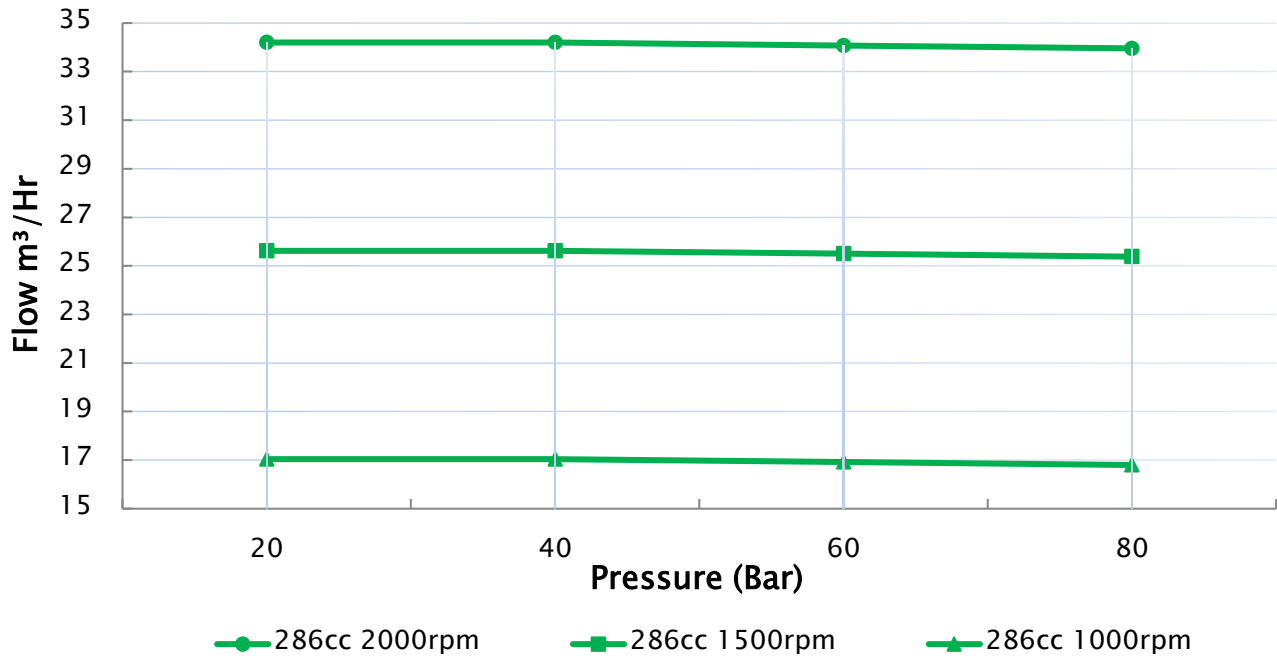

### Input Power

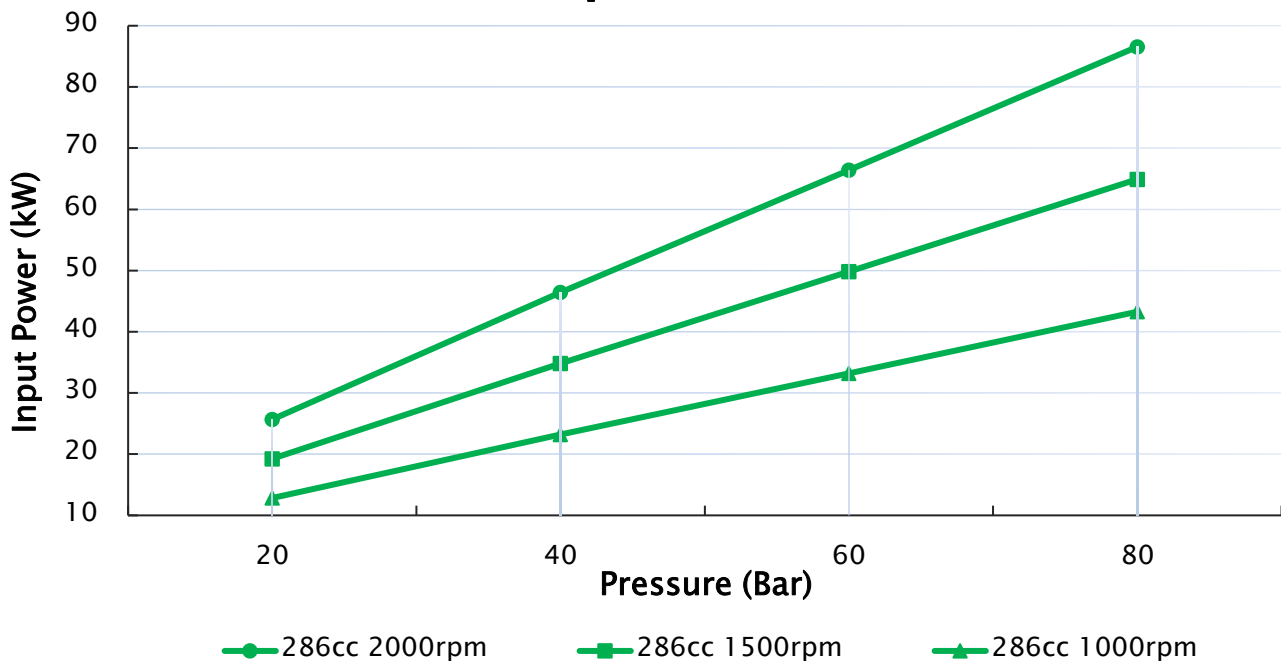

# SEAWATER AXIAL PISTON PUMPS

## Input Torque

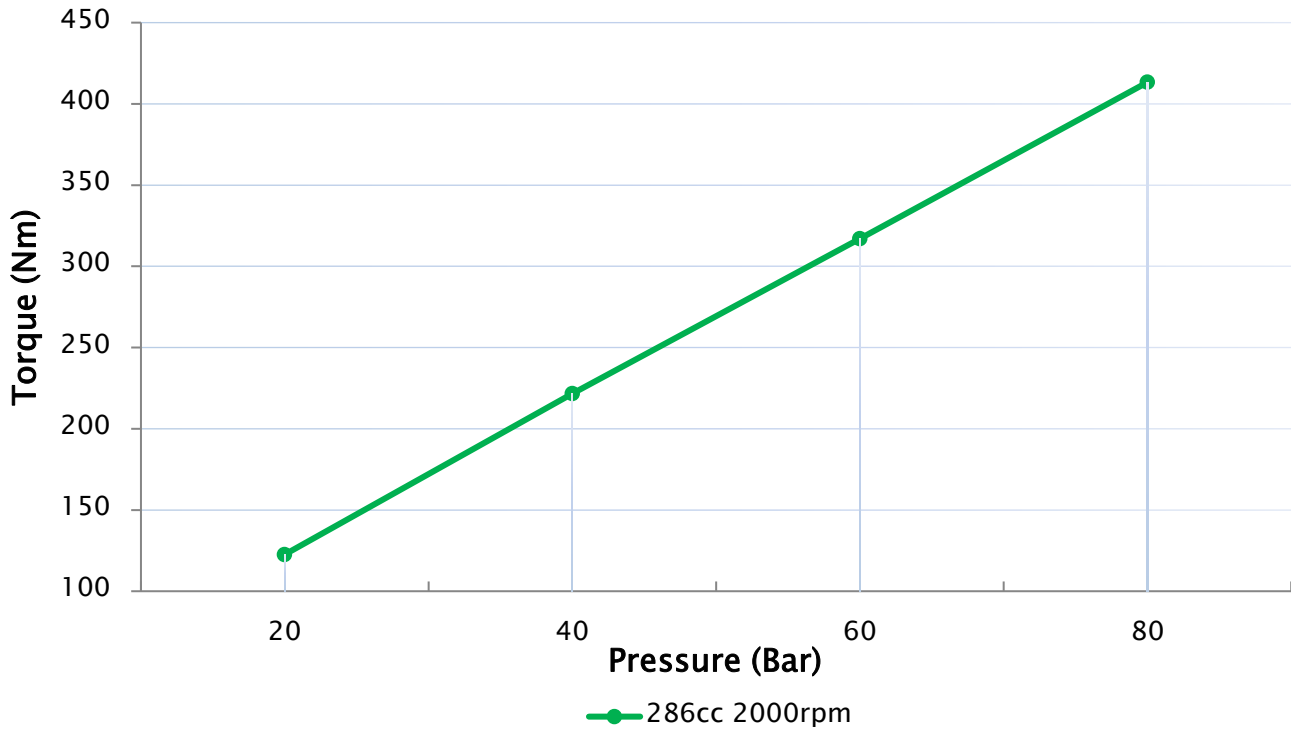

## Overall Efficiency

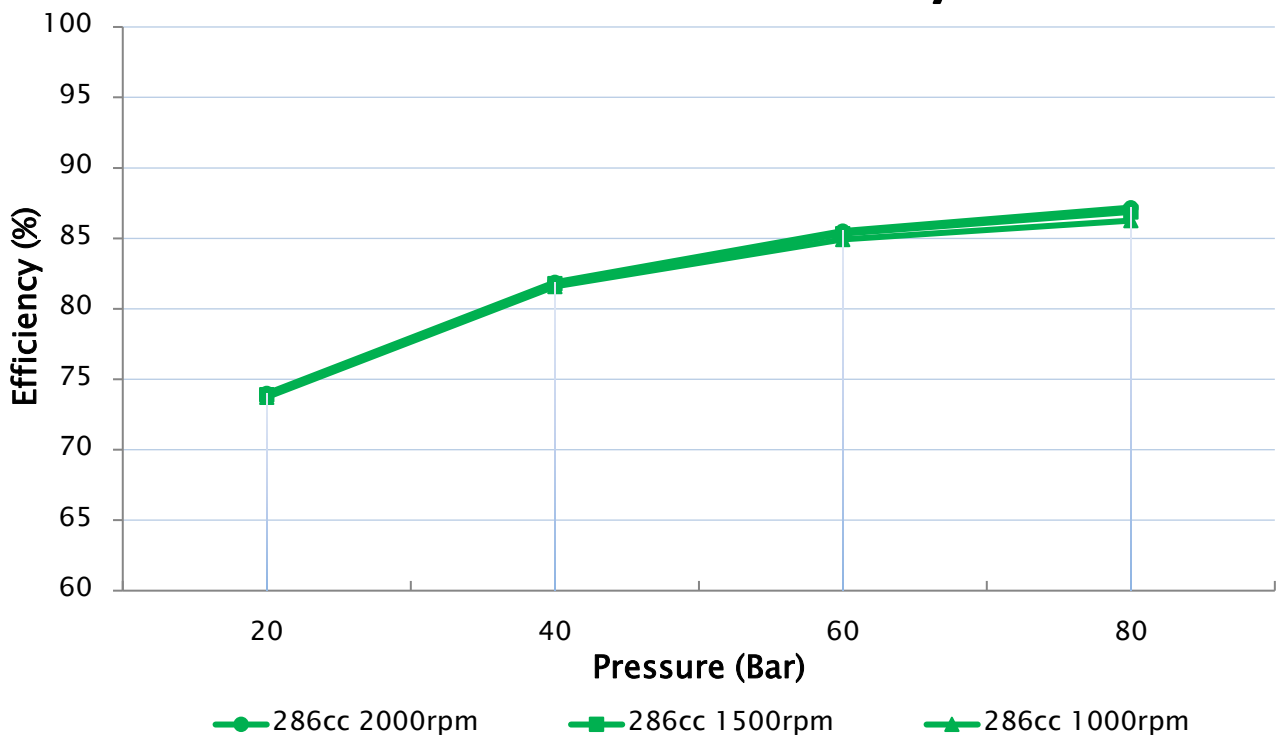

# SEAWATER AXIAL PISTON PUMPS

## 3.7 P600

### 3.7.1 Specification

SPECIFICATION					
Displacement (cc/rev)			390	444	625
Max. RPM	Boosted: *		1250	1250	1250
Max. Input Power (kW)			72.3	82.3	115.8
Max. Water Flow (m <sup>3</sup> /hr)			29.2	33.3	46.8
Max. Cont. Pressure (Barg)			80	80	80
Weight (kg)			120	120	120
Temperature (°C)	Max: **		50	50	50
	Min: ***		2	2	2

### 3.7.2 General Assembly Drawing

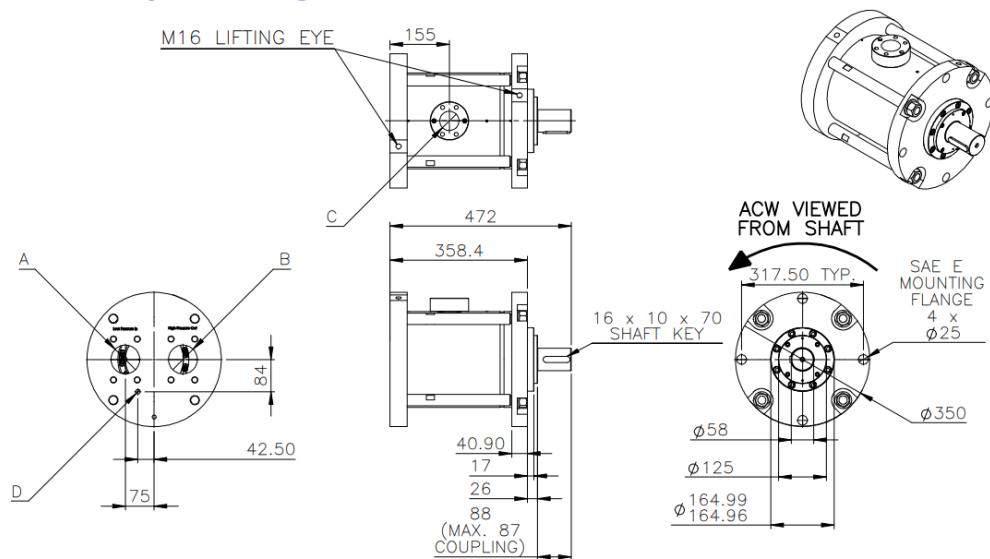

### 3.7.3 Port Dimensions (ACW Configuration)

Position	Description	Size
A	Low Pressure In	3" 3000 PSI CLASS SAE 4-BOLT FLANGE
B	High Pressure Out	3" 3000 PSI CLASS SAE 4-BOLT FLANGE
C	Case Drain	1 1/2" 3000 PSI CLASS SAE 4-BOLT FLANGE
D	Inlet Pressure Switch Port	1/4" BSPP FEMALE

# SEAWATER AXIAL PISTON PUMPS

## 3.7.4 P600 Performance Data

### Output Flow

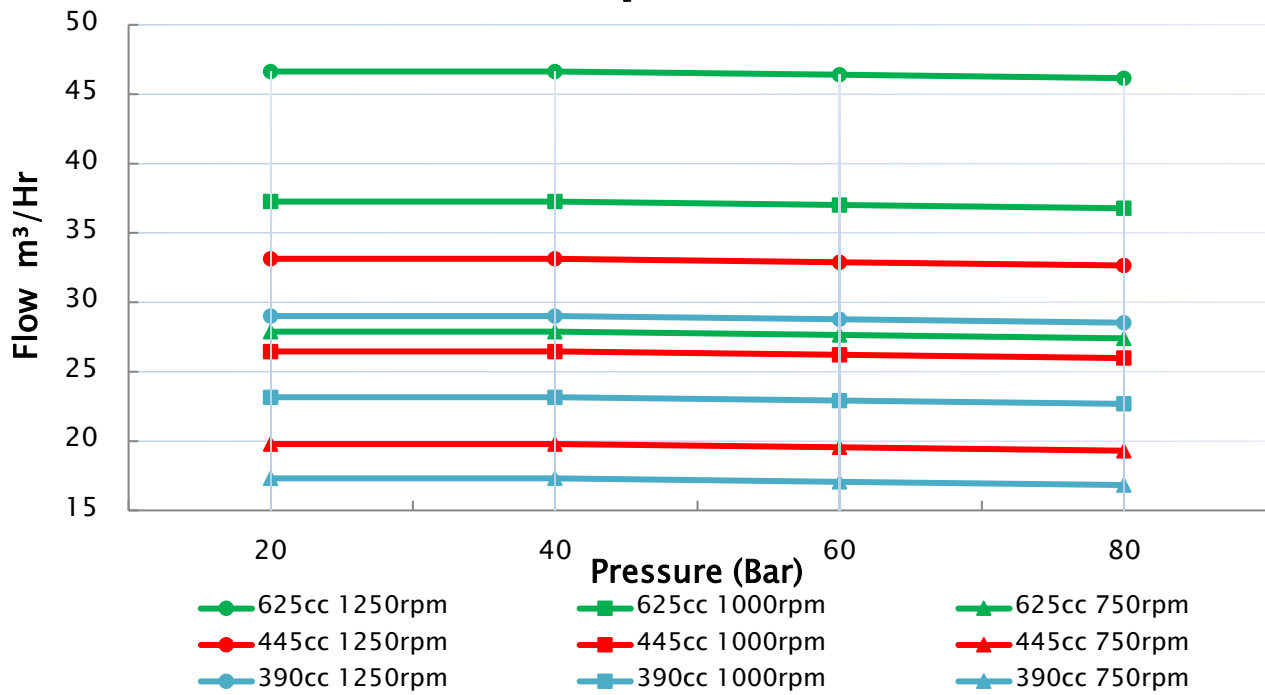

### Input Power

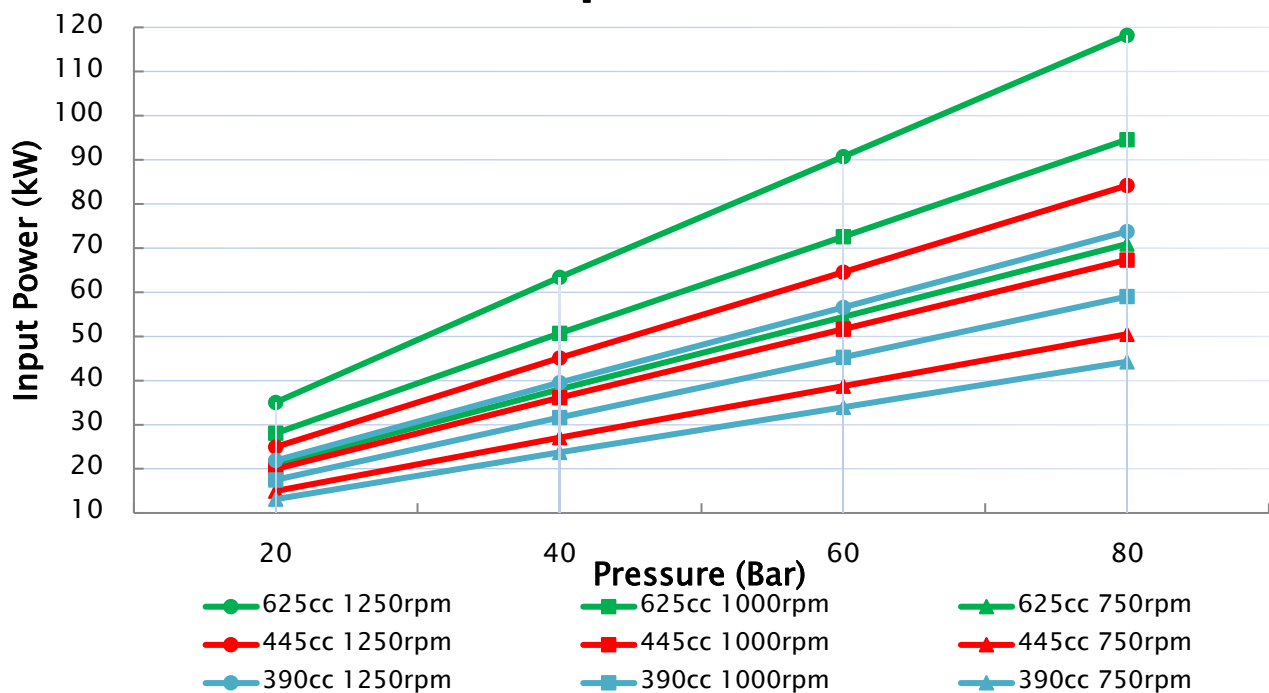

# SEAWATER AXIAL PISTON PUMPS

## Input Torque

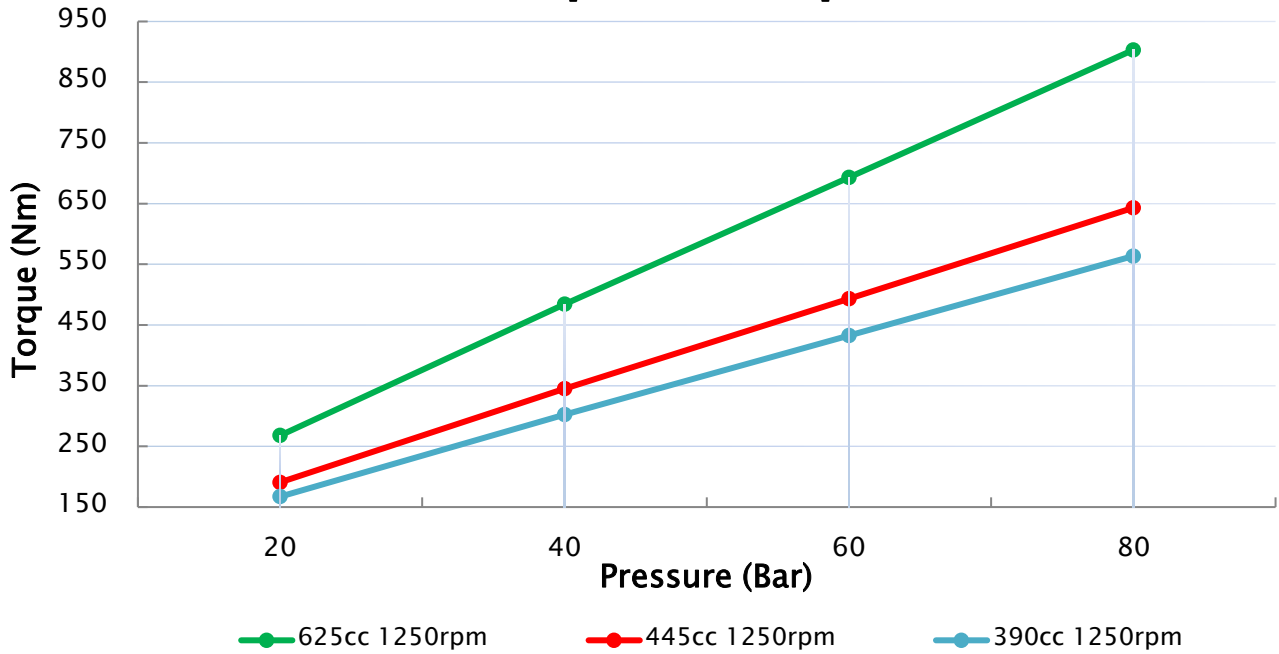

## Overall Efficiency

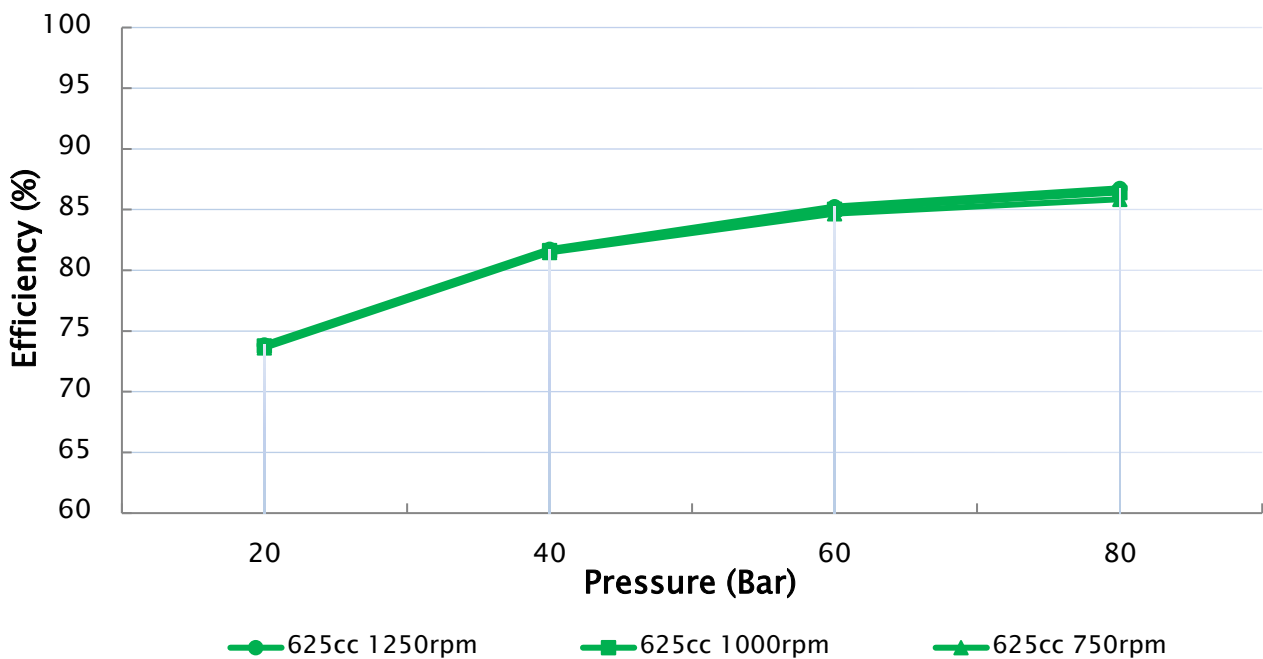

# SEAWATER AXIAL PISTON PUMPS

## 4. SYSTEM DESIGN

### 4.1 Circuit Example

Below is a typical circuit diagram detailing how the pumps should be set up.

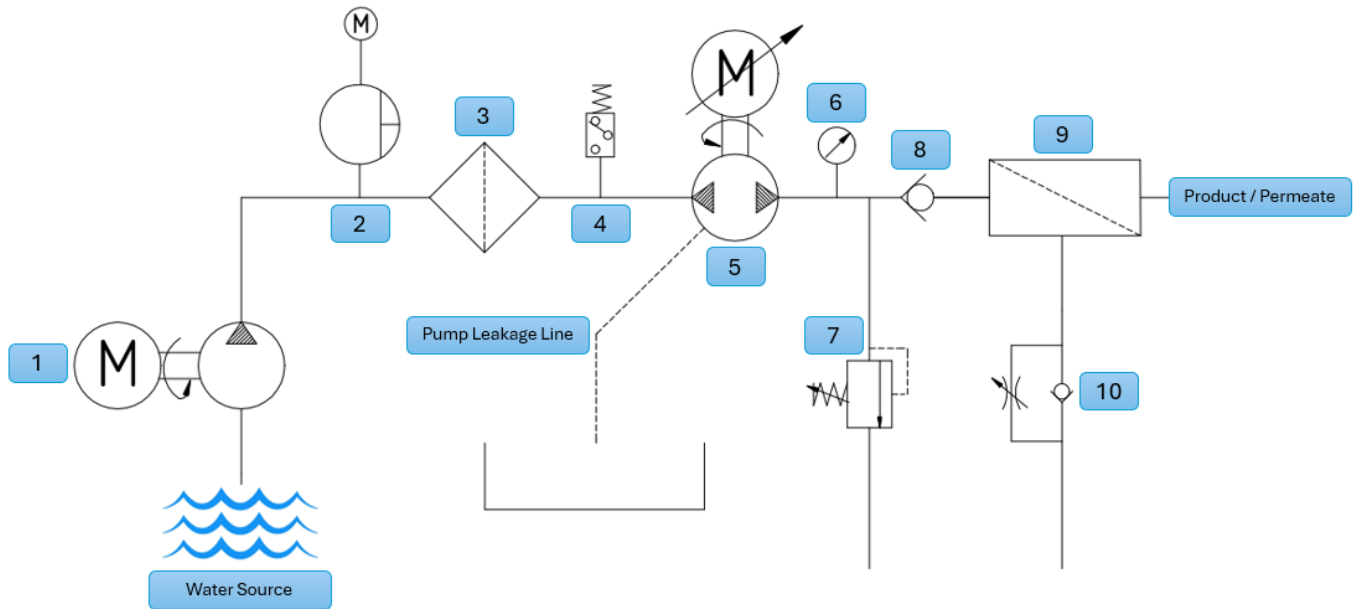

Item	Component	Function
1	Feed / Boost Pump	Ensure water is fed to the pump inlet at required inlet pressure.
2	Dosing Pump	Deliver chemicals such as Antiscalant, coagulants, pH adjusters, biocides, or chlorine neutralizers into the feedwater stream.
3	Filter	Ensure pumps minimum filtration requirements are met. (Beta Ratio > 5000)
4	Inlet Protection Pressure Switch	Ensures a continuous minimum pressure at the pump's inlet. If the minimum is not achieved the system must shut down to avoid pump damage.
5	Axial Piston Pump	The Water Hydraulics Axial Piston Pump and variable frequency speed driven electric motor, 80 bar maximum working pressure.
6	Pressure Gauge	Used to measure and display the operating pressure after the pump within the system.
7	Pressure Relief Valve	Ensure the system pressure does not exceed the maximum working pressure (80 Bar).
8	Check Valve	A high-pressure check valve must be installed to prevent back driving of the axial piston pump.
9	RO Membrane	Separating the useful product water from the unwanted brine solution.
10	Flow Control Valve	Sets the system pressure desired.

# SEAWATER AXIAL PISTON PUMPS

## 4.2 Electric Motor

A standard range of bell housings and couplings are available for connecting the pumps to the B35 electric motor flange. See our Desalination Motor Pump Assembly datasheet for further information on potential combinations. The pumps cannot operate with induced axial or radial loads on the output shaft; always adopt the use of a 3-part gear style flexible coupling where possible. If the drive shaft/spigot location is within 0.05mm concentricity, direct inline drive assemblies are permissible.

Symbol	Description	Unit
P	Shaft Power	kW
Q	Flow Rate	L/min
$\Delta p$	Change in Pressure	Bar

Use the calculation below to determine the motor power requirement depending on the maximum operating pressure and flow rate.

$$P = \frac{Q \times \Delta p}{600} \div 0.9$$

Example:

A P60 pump with an output flow of 140 L/min at a maximum working pressure of 80 Bar.

$$P = \frac{140 \times 80}{600} \div 0.9 = 20.7 \text{ kW}$$

## 4.3 Installation

The adjacent diagram illustrates the correct method for installing the pump onto an electric motor using a three-part, gear-type flexible coupling.

Ensure that no axial or radial loads are applied to the pump during installation.

For further guidance on installation components or assembly requirements, please contact TWHC.

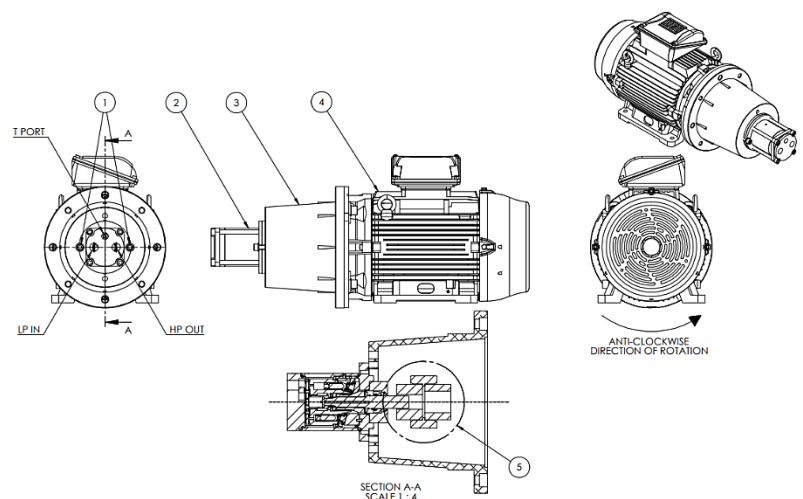

Item No.	Description
1	Mounting Bolts & Washers
2	TWHC Pump Unit
3	Bellhousing
4	Electric Motor
5	3-Part Gear Style Flexible Coupling

# SEAWATER AXIAL PISTON PUMPS

## 5. SERVICING

### 5.1 Service Schedule

Servicing at the recommended intervals will prolong unit life and guarantee optimal performance from your TWHC product. See the table below for service intervals.

Interval	Service Type	Work Required
5 Years	O-Ring Replacement	<ul style="list-style-type: none"> <li>- Replace all O-rings</li> <li>- Clean &amp; Re-assemble</li> <li>- Check Performance</li> </ul>
8000 hrs.	Inspection Service	<ul style="list-style-type: none"> <li>- As above</li> <li>- Inspection to ensure condition with checks for corrosion, wear rate and contamination.</li> <li>- Mechanical seal inspection (replace if necessary)</li> </ul>
20000 hrs.	Major Service	<ul style="list-style-type: none"> <li>- As above</li> <li>- Rotating assembly replacement</li> <li>- Re-working or replacement port plate</li> <li>- Bearing surfaces re-finished</li> <li>- Bearing replacement if required</li> <li>- Mechanical seal replacement</li> </ul>

TWHC offer a service exchange scheme where a direct replacement can be offered in exchange for a unit which requires a service. Please consult with TWHC beforehand to check availability.

# SEAWATER AXIAL PISTON PUMPS

## 6. DISCLAIMER

Whilst every endeavor has been made to ensure accuracy, this publication cannot be considered to represent part of any contract, whether expressed or implied. The publishers reserve the right to amend specifications at their discretion.

## 7. CONTACT DETAILS

For any additional information or serviceable parts contact:

**The Water Hydraulics Co. Ltd.**

**Alexandra House  
English Street  
Hull  
HU3 2DJ  
East Yorkshire  
United Kingdom**

**Tel: +44 (0) 1482595000**

**Email: [sales@waterhydraulics.co.uk](mailto:sales@waterhydraulics.co.uk)**

**Website: [www.waterhydraulics.co.uk](http://www.waterhydraulics.co.uk)**